

تُقُولِ حِکْمَتِ

انزائی

علامہ نصیر الدین نصیر ہونزائی

شائع کردہ

خانہ حکمت — ادارہ عارف

Diagrams of Wisdom

(Nuqūsh-i Hikmat)

ISW
LS

by

ALLĀMAH

NASĪR AL-DĪN "NASĪR" HUNZĀ'Ī

Institute for
Spiritual Wisdom
and
Luminous Science

Knowledge for a united humanity

Published by:

KHĀNAH-I HIKMAT/IDĀRAH-I ĀRIF

3-A, Noor Villa, 269 Garden West,
Karachi-3 (Pakistan)

Zulfiqarabad, Gilgit (Pakistan)

بِسْمِ اللَّهِ الرَّحْمَنِ الرَّحِيمِ

ISLAM

IS HE WHO GOETH GROPING ON HIS FACE MORE
RIGHTLY GUIDED, OR HE WHO WALKETH UPRIGHT
ON A BEATEN ROAD? (67: 22)

THE HOUSE OF ALLAH

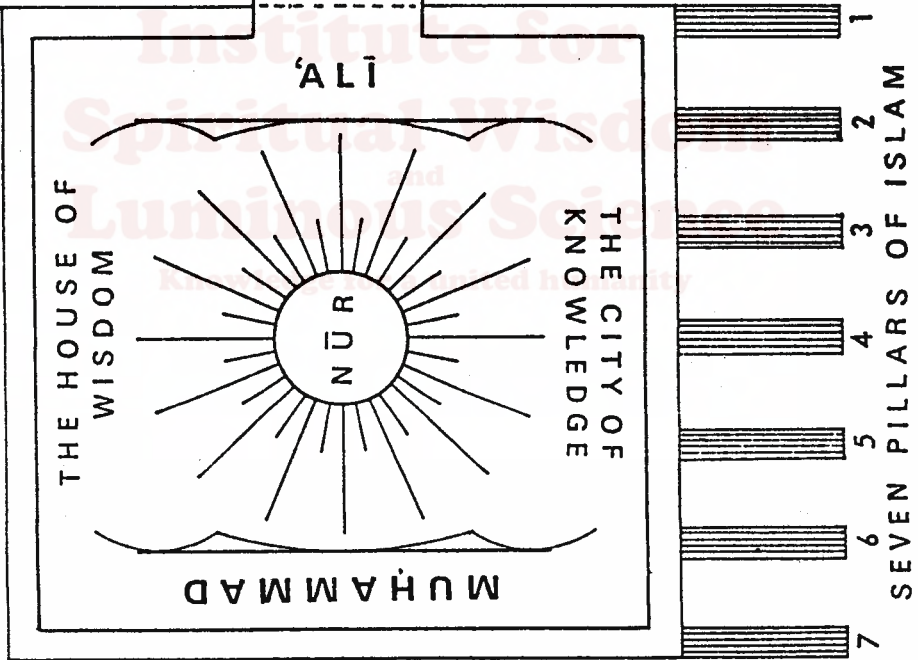

SEVEN PILLARS OF ISLAM

IT IS RELATED FROM IMĀM MUHAMMAD AL-BĀQIR: ISLĀM IS BASED ON SEVEN PILLARS:

(1) WALĀYA (DEVOTION TO THE IMĀM) OR, WILĀYA (POWER, AUTHORITY) AND THIS IS MOST EXCELLENT : AND THROUGH IT AND THE IMAM, THE TRUE KNOWLEDGE OF THE FAITH CAN BE OBTAINED.

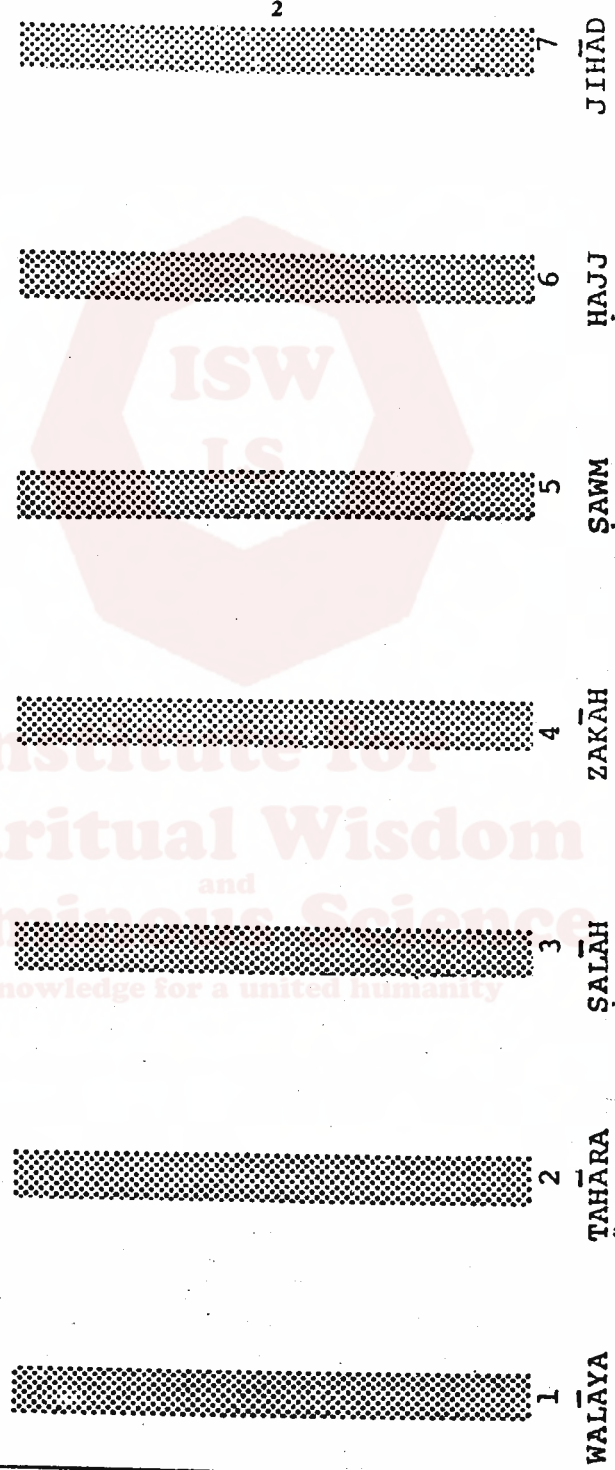

(2) TAHĀRA (RITUAL PURITY) (3) ṢALĀH (PRAYER) (4) ZAKĀH (POOR TAX) (5) ṢAWM (FASTING) (6) HĀJJ (PILGRIMAGE) AND (7) JIHĀD (HOLY WAR)

THE BOOK OF FAITH

THE HOLY QUR'ĀN AND IMĀM

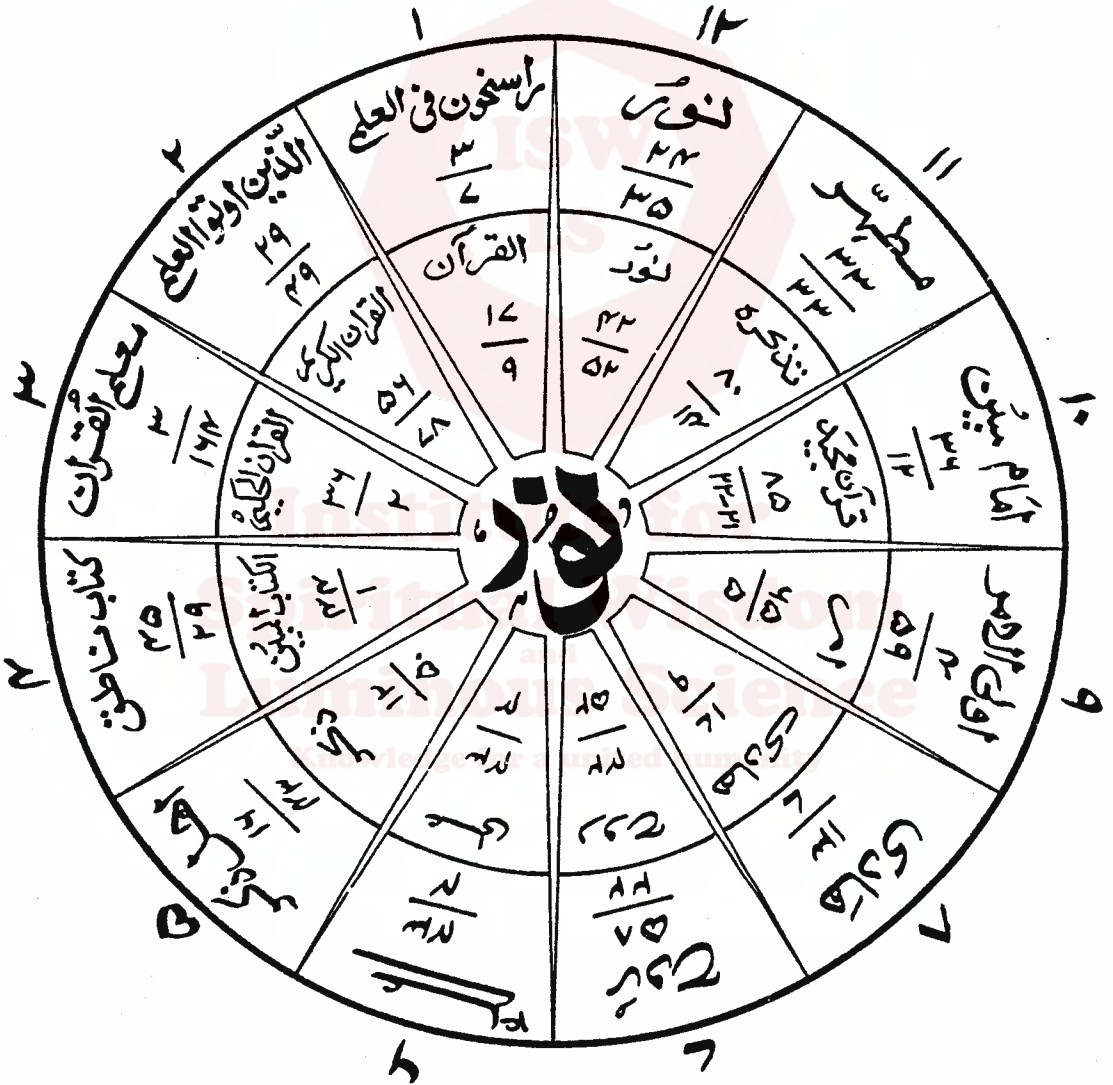

THE WISDOM OF SOME NAMES OF THE HOLY QUR'ĀN AND THE IMĀM

QUR'ĀN	IMĀM	QUR'ĀN	IMĀM
COMMAND 65:5	COMMANDER 4:59	GUIDANCE 2:97	GUIDE 13:7
SOUL 42:52	SOUL 58:22	BOOK 5:15	LIGHT 5:15
DHIKR 21:50	AHL-I DHIKR 16:43	BOOK 3:164	DIVINE TEACHER 3:164
SILENT-BOOK 16:64	SPEAKING-BOOK 45:29	TADHKIRAH 80:11	SUHUF 80:13
GLORIOUS QUR'ĀN 85:21	GUARDED TABLET 85:22	MUKHAM AND MUTASHABIH 3:7	RĀSIKH FĪ- AL-'ILM 3:7
'ALĪ 43:4	UMM AL-KITĀB 43:4	'ILM 3:61	'ALIM 29:49
HERITAGE 35:32	HEIR 35:23	NOBLE QUR'ĀN 56:77	HIDDEN BOOK 56:78

THE HOLY QUR'ĀN

SEE YE NOT HOW ALLAH HATH MADE SERVICEABLE UNTO YOU WHATSOEVER IS IN THE SKIES AND WHATSOEVER IS IN THE EARTH AND HATH LOADED YOU WITH HIS FAVOURS BOTH WITHOUT (ẒĀHIR) AND WITHIN (BĀṬIN)? (31 : 20)

TANZĪL = ẒĀHIR = KITĀB

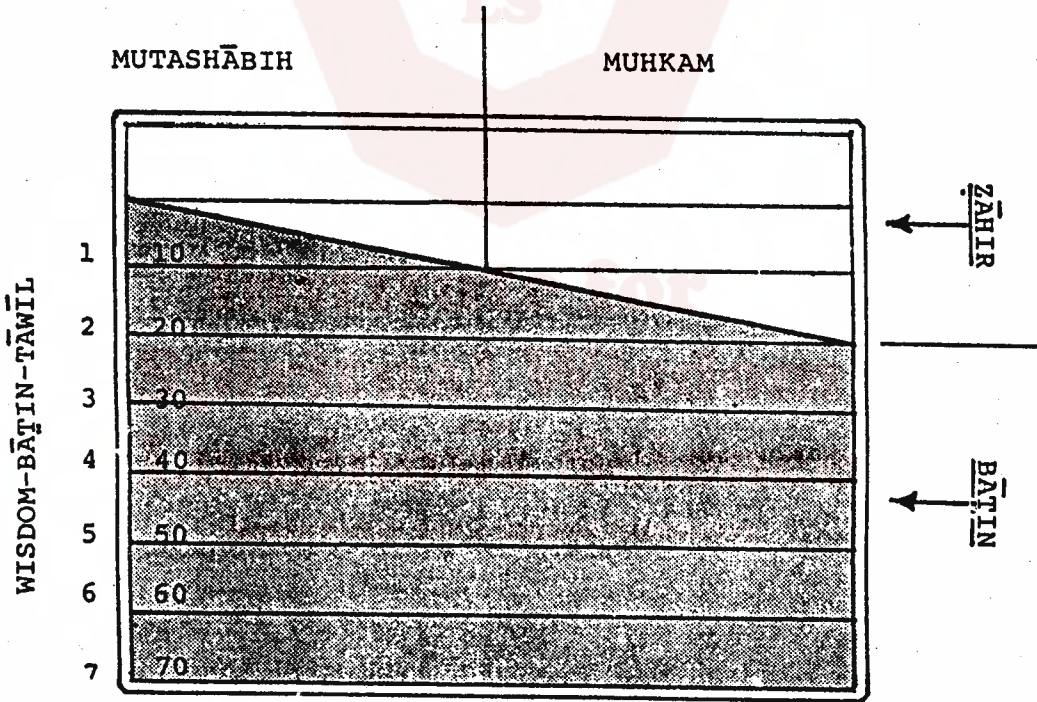

7 OR 70 INWARD (ESOTERIC) MEANINGS OF EVERY ĀYAT OF THE HOLY QUR'ĀN

THE HOLY QUR'ĀN

WE SHALL SHOW THEM OUR SIGNS (ĀYATS) ON THE HORIZONS AND WITHIN THEMSELVES UNTIL IT WILL BE MANIFEST UNTO THEM THAT IT IS THE TRUTH. (41 : 53)

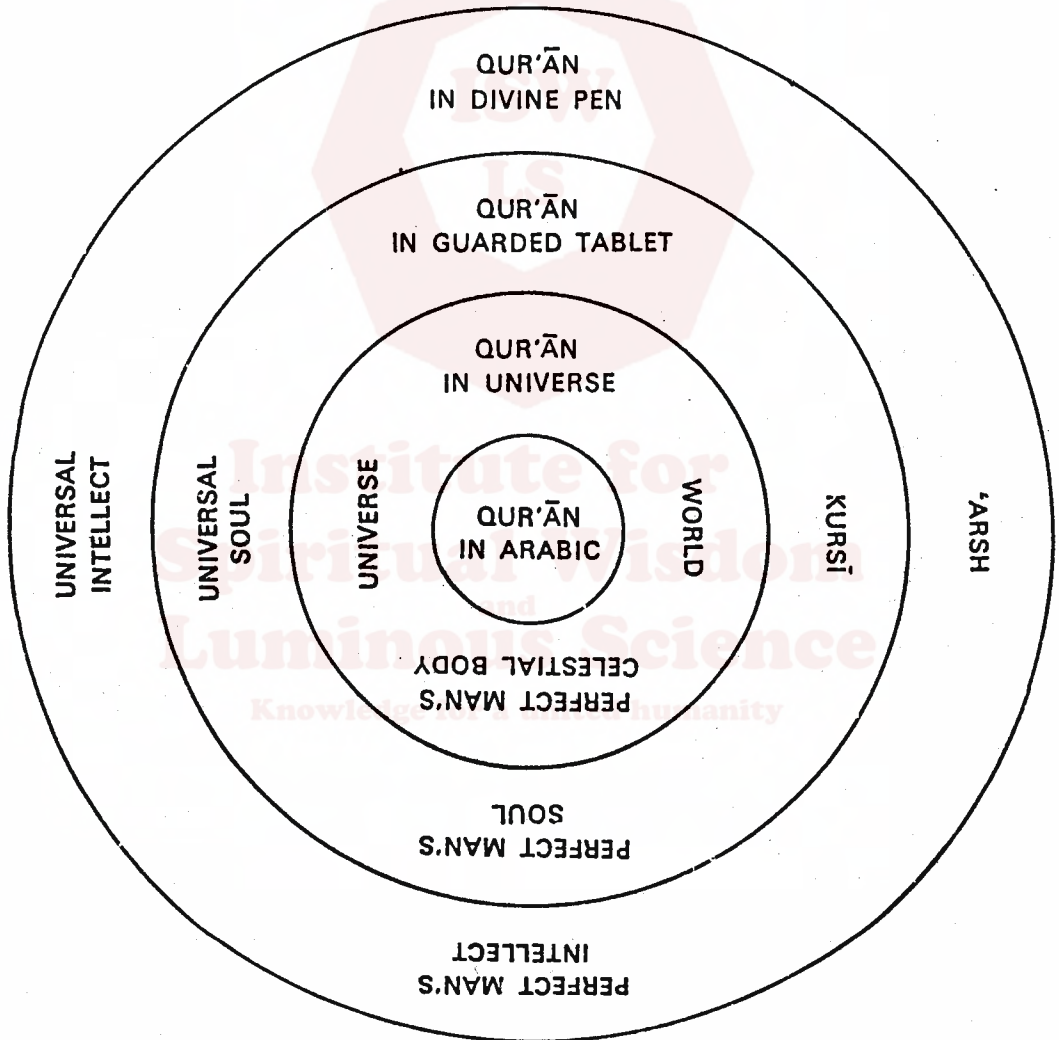

LOI IN THE HEAVENS AND THE EARTH ARE PORTENTS FOR BELIEVERS. (45 : 3)

THE HOLY QUR'ĀN

AND THERE IS NOT A THING BUT WITH US ARE THE TREASURES THEREOF.
AND WE SEND IT NOT DOWN SAVE IN APPOINTED MEASURE. (15: 21)

QUR'ĀN IN FORMER SCRIPTURES

QUR'ĀN IN MASHAF

QUR'ĀN IN FĀTIḤAH

QUR'ĀN IN BISMILLĀH

QUR'ĀN IN BĀ' OF BISMILLĀH

QUR'ĀN IN DOT

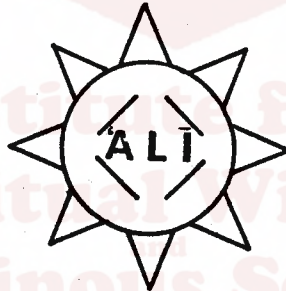

QUR'ĀN IN NUQTA

QUR'ĀN IN LETTER

QUR'ĀN IN ISM

QUR'ĀN IN UMM AL-KITĀB

QUR'ĀN IN MANIFEST BOOK

QUR'ĀN IN FORMER MYSTIC BOOKS

I AM THE DOT OF BĀ' IN BISMILLĀH. (MAWLĀ 'ALĪ)

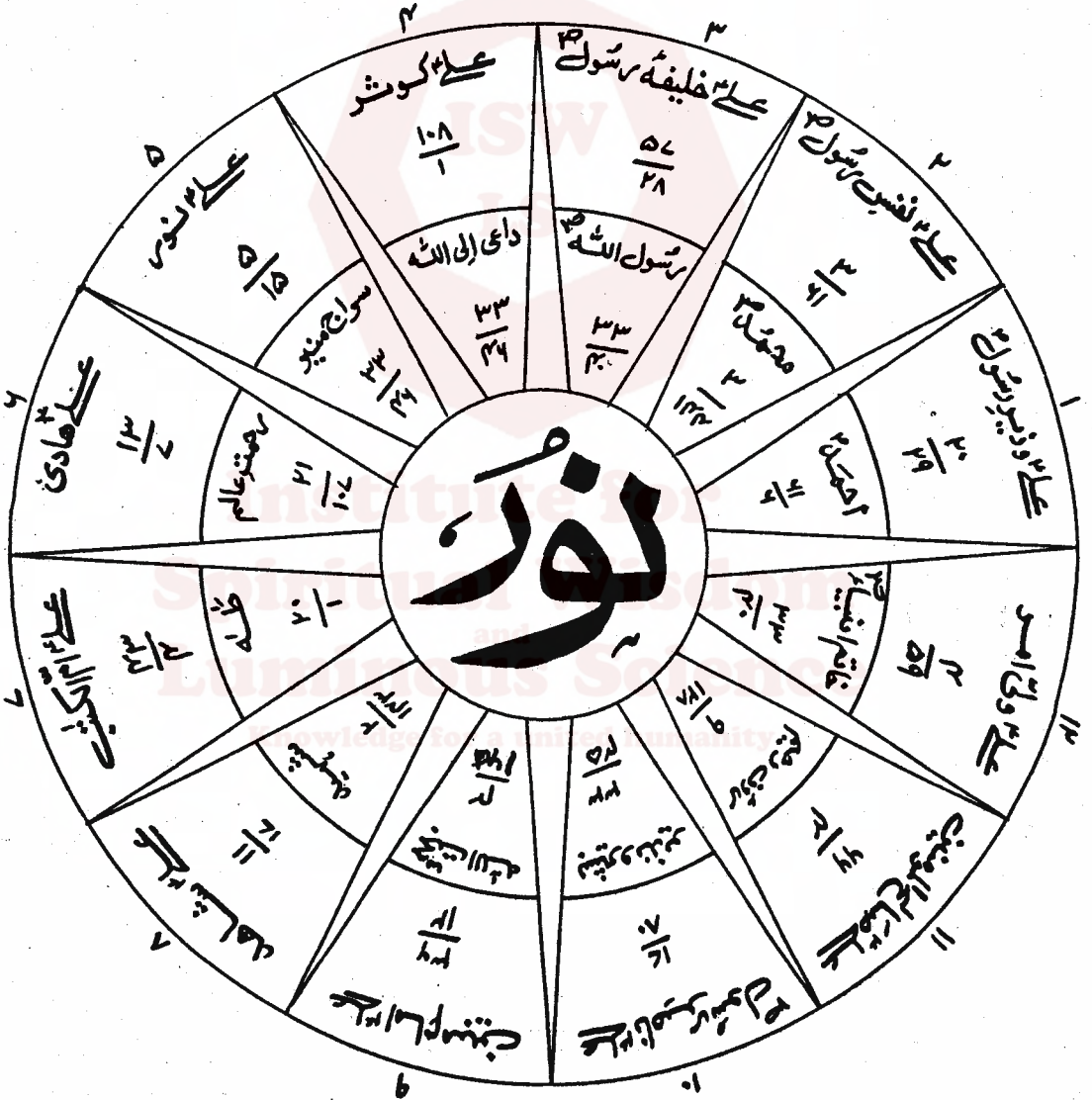

SOME OF THE MYSTERIOUS NAMES OF THE HOLY PROPHET AND THE IMAM

PROPHET	IMAM	PROPHET	IMAM
MESSENGER 13:43	WITNESS 13:43	ON A CLEAR PROOF 11:17	TĀLĪ AND WITNESS 11:17
WITNESS OVER A'IMMAH 2:143	WITNESS OVER MANKIND 2:143	PROPHET 39:69	WITNESS 39:69
MESSENGER 20:29	WAZIR 20:29	MESSENGER 17:80	MIGHTY ASSISTANT 17:80
PROPHET 5:55	GUARDIAN 5:55	WARNER 13:7	GUIDE 13:7
PROPHET 66:4	SĀLĪH-U AL-MU'MINĪN 66:4	RASŪL 3:61	SELF OF RASŪL 3:61
LUMINOUS LAMP 33:46	NŪR 57:28	TRUTHFUL 9:119	TRUTHFUL 9:119
THE HAND OF ALLAH 48:10	THE HAND OF ALLAH 48:10	DHIKR 65:10-11	AHL-I DHIKR 16:43

TREE OF KNOWLEDGE

10

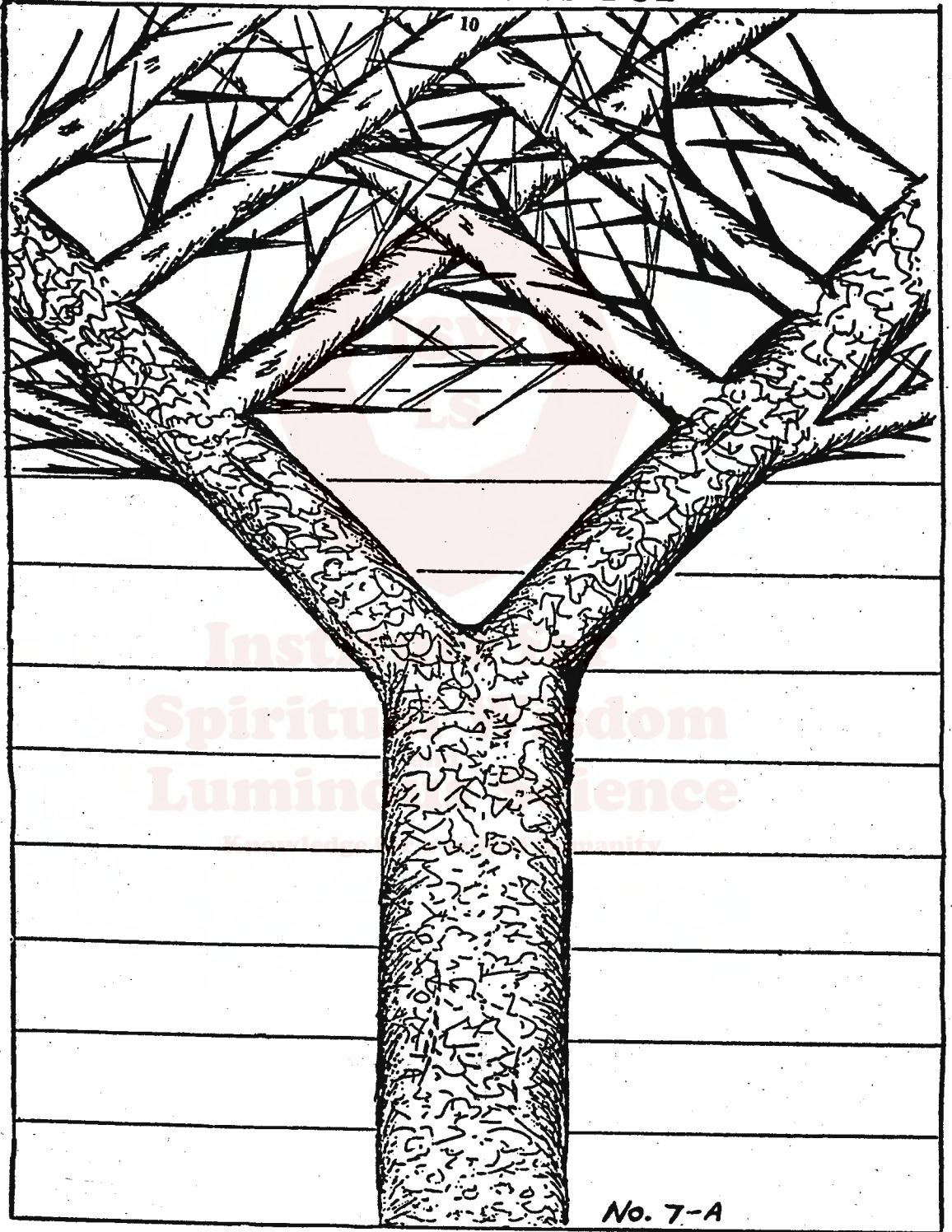

No. 7-A

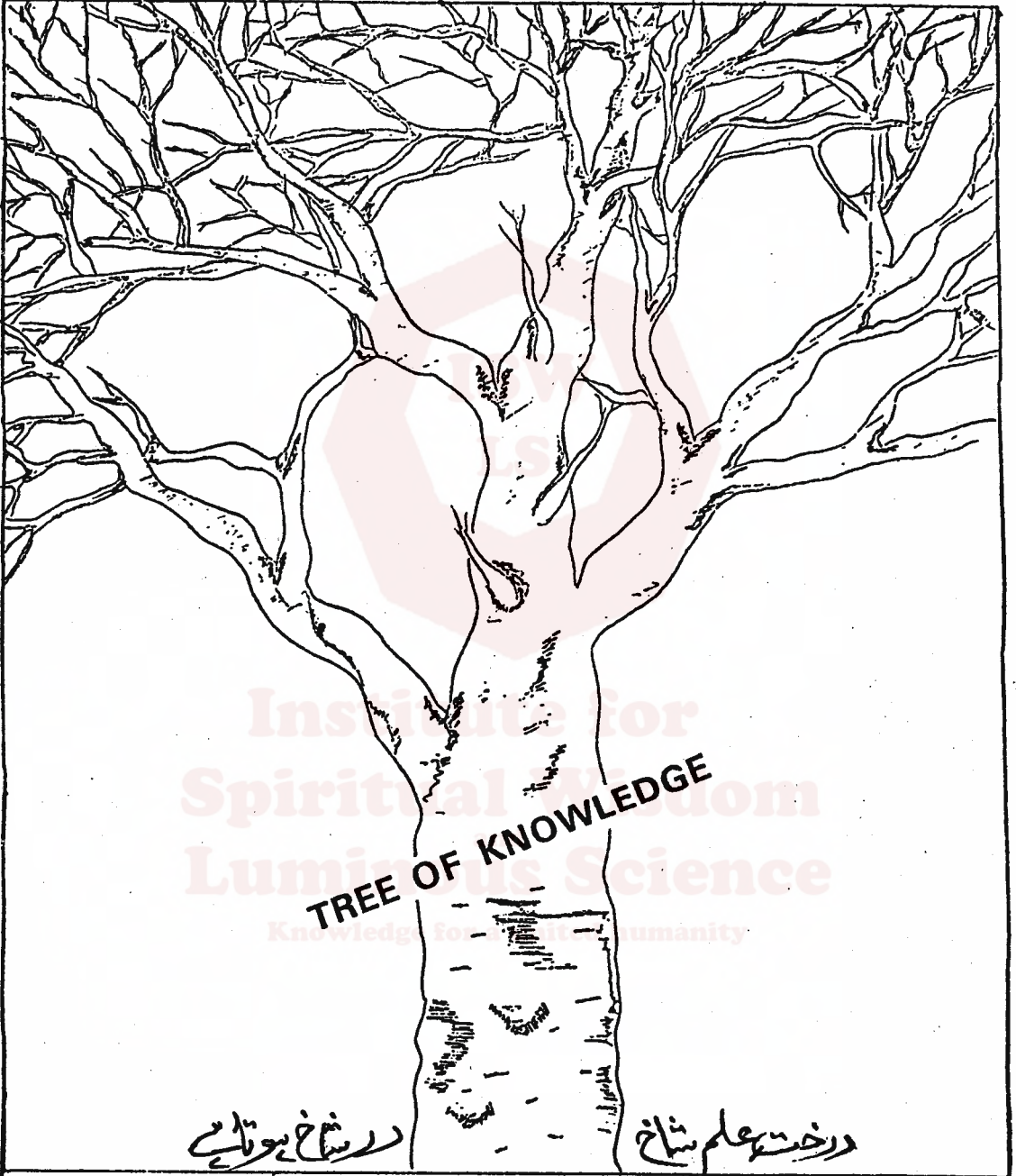

درخت علم ہوتا ہے

درخت علم شاخ

EXISTENCE

OUR LORD THOU COMPREHENDEST ALL THINGS IN MERCY
AND KNOWLEDGE, THEREFORE FORGIVE THOSE WHO REPENT AND
FOLLOW THY WAY. (40:7)

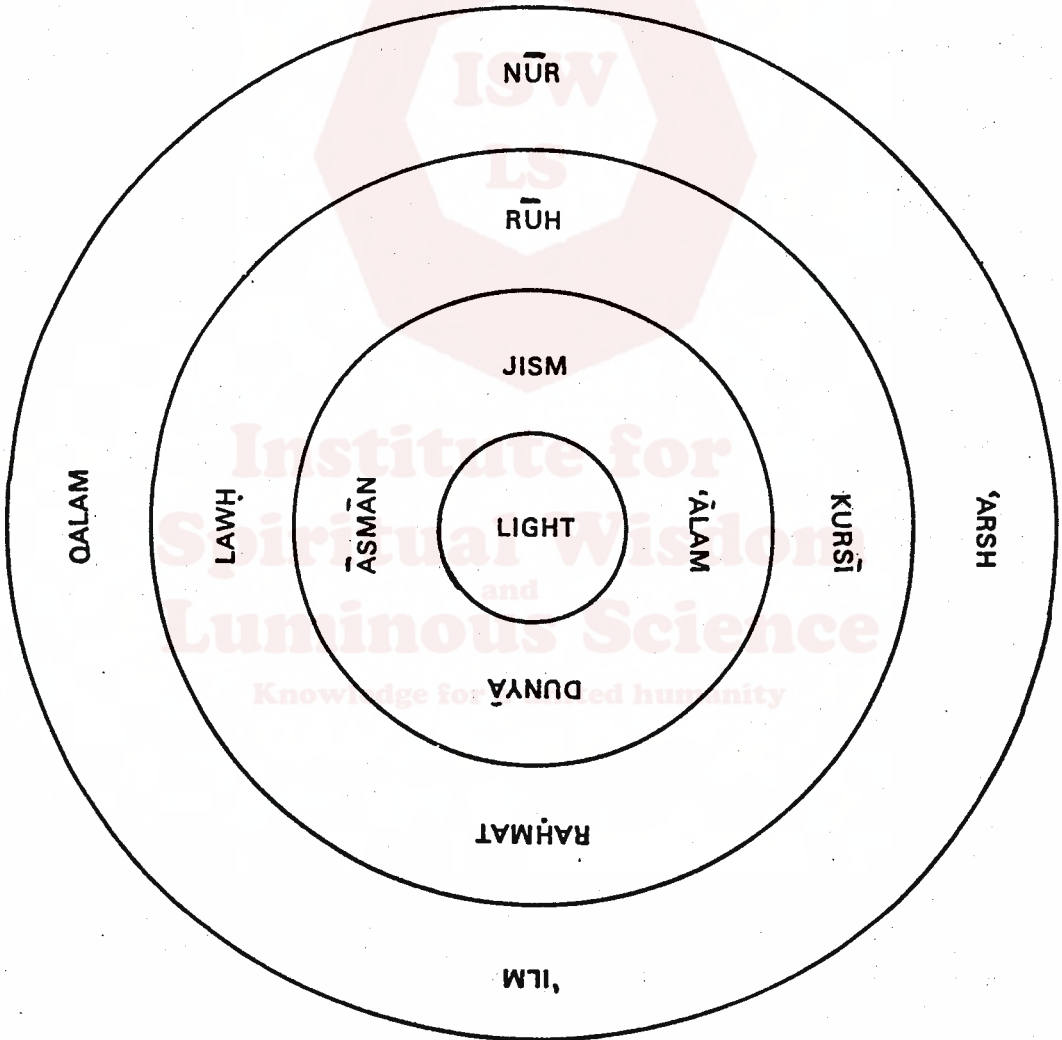

AN EXAMPLE OF SPIRITUAL AND PHYSICAL EXISTENCE.

No. 8(A)

EXISTENCE

HIS KURSI INCLUDETH THE HEAVENS AND THE EARTH, AND HE IS NEVER WEARY OF PRESERVING THEM. HE IS THE SUBLIME, THE TREMENDOUS. (2: 255)

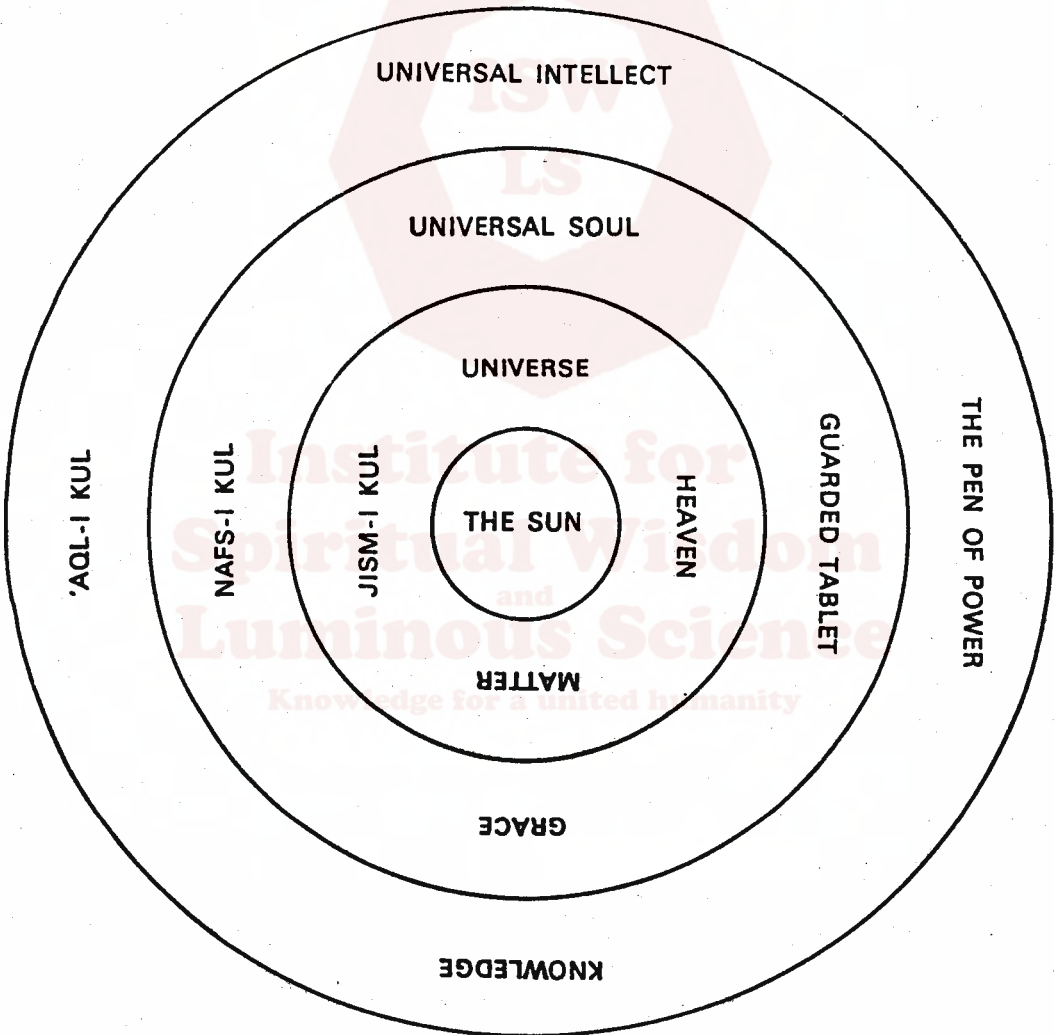

AN EXAMPLE OF SPIRITUAL AND PHYSICAL EXISTENCE.

49 STARS IN 'ALĪ

AND LANDMARKS (TOO), AND BY THE STAR THEY FIND A WAY (16: 16)

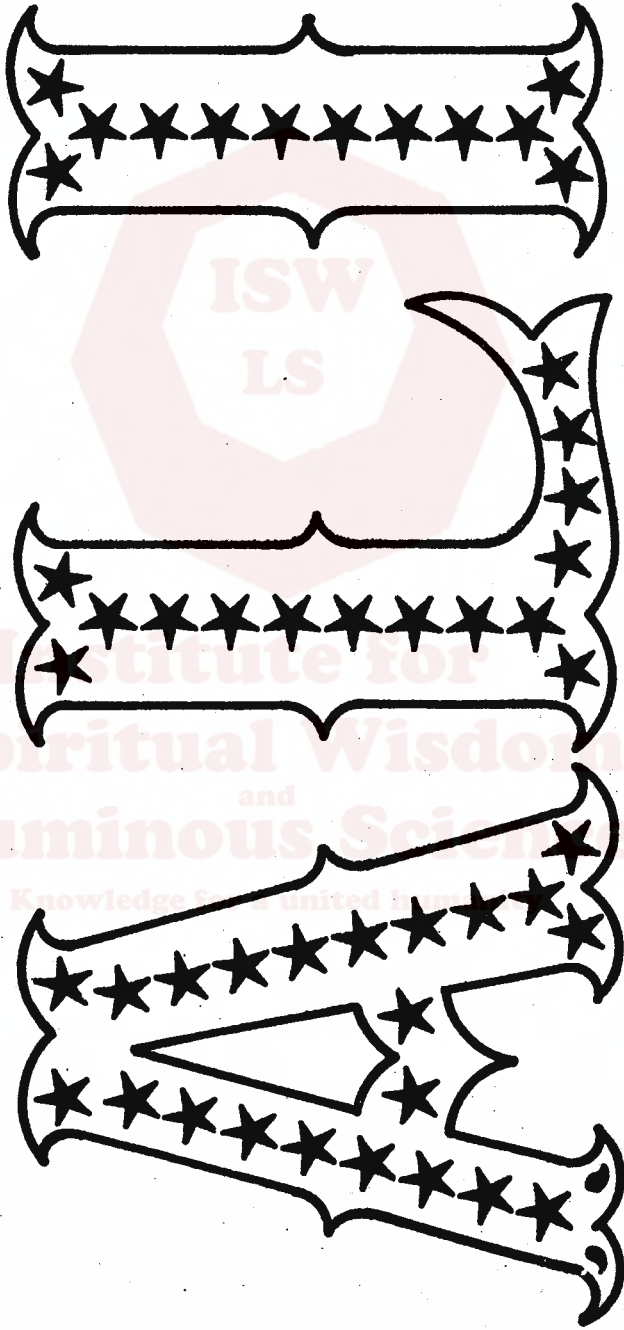

NOTE: ACCORDING TO THE HOLY QUR'ĀN (LIGHT UPON LIGHT 24: 35) ALL IMĀMS ARE ONE AND THE SAME IN 'ALĪ.

49 STARS IN 'ALI

AND HE IT IS WHO HATH SET FOR YOU THE STARS THAT YE MAY
GUIDE YOUR COURSE BY THEM AMID THE DARKNESS OF THE LAND
AND THE SEA. WE HAVE DETAILED OUR REVELATIONS (AYATS) FOR
A PEOPLE WHO HAVE KNOWLEDGE. (6: 97)



NOTE: PROPHETS AND IMAMS ARE LIKE SINGLE SOUL AND MOMINS ARE AS BROTHERS, AND IT IS IN THE LIGHT OF QUR'AN AND HADITH.

No.10-B

49 STARS IN 'ALI

WHEREAS IF THEY HAD REFERRED IT TO THE MESSENGER AND SUCH OF THEM AS ARE IN AUTHORITY, THOSE AMONG THEM WHO ARE ABLE TO THINK OUT THE MATTER WOULD HAVE KNOWN IT. (4: 83)

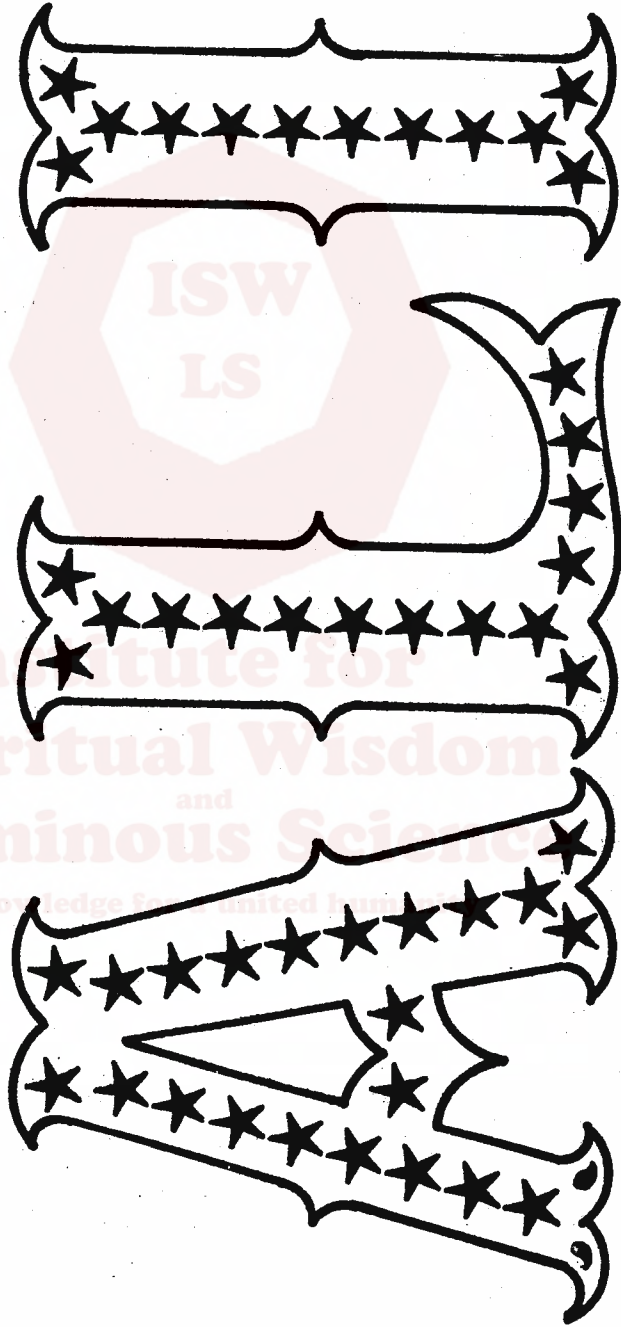

NOTE: THE IMĀMS OF THE HOUSE OF THE PROPHET HAVE THE DIVINE AUTHORITY AND THEY ARE ŪLU'L-AMR.

49 STARS IN 'ALI

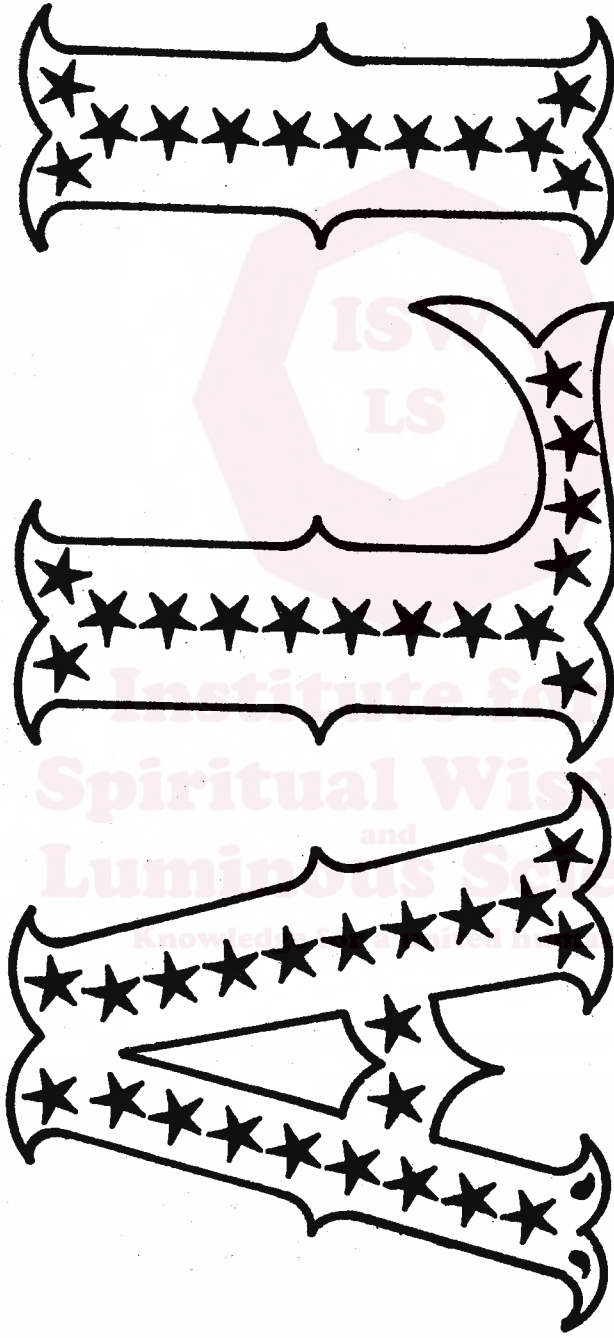

THUS WE HAVE APPOINTED YOU A MIDDLE NATION (UMMATAN WASATAN MEANING A "JUST NATION") THAT YE BEAR WITNESS AGAINST MANKIND, AND THAT THE MESSENGER MAY BE A WITNESS AGAINST YOU. (2: 143)

49 STARS IN 'ALĪ

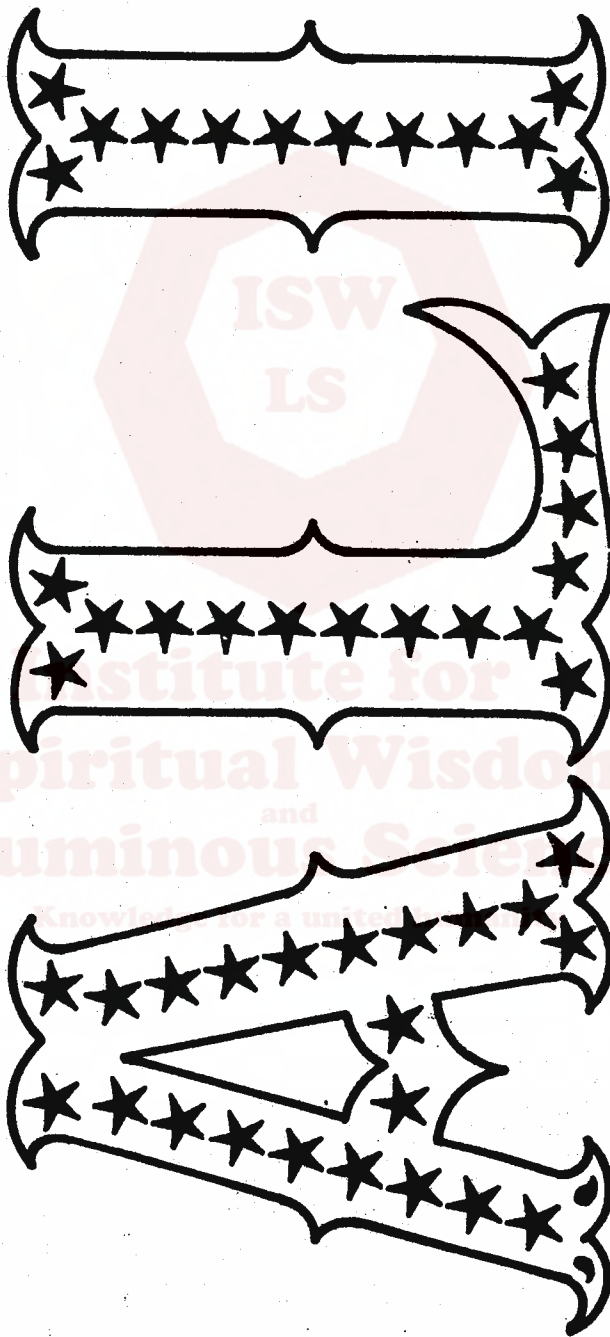

BUT IT (QUR'ĀN) IS CLEAR REVELATIONS (MIRACLES) IN THE
HEARTS OF THOSE WHO HAVE BEEN GIVEN KNOWLEDGE (29: 43)

نزل القرآن اربع ارباع -
 قرآن چار جوتھا میوں میں نازل ہوئے
 (کلام مولانا علی)

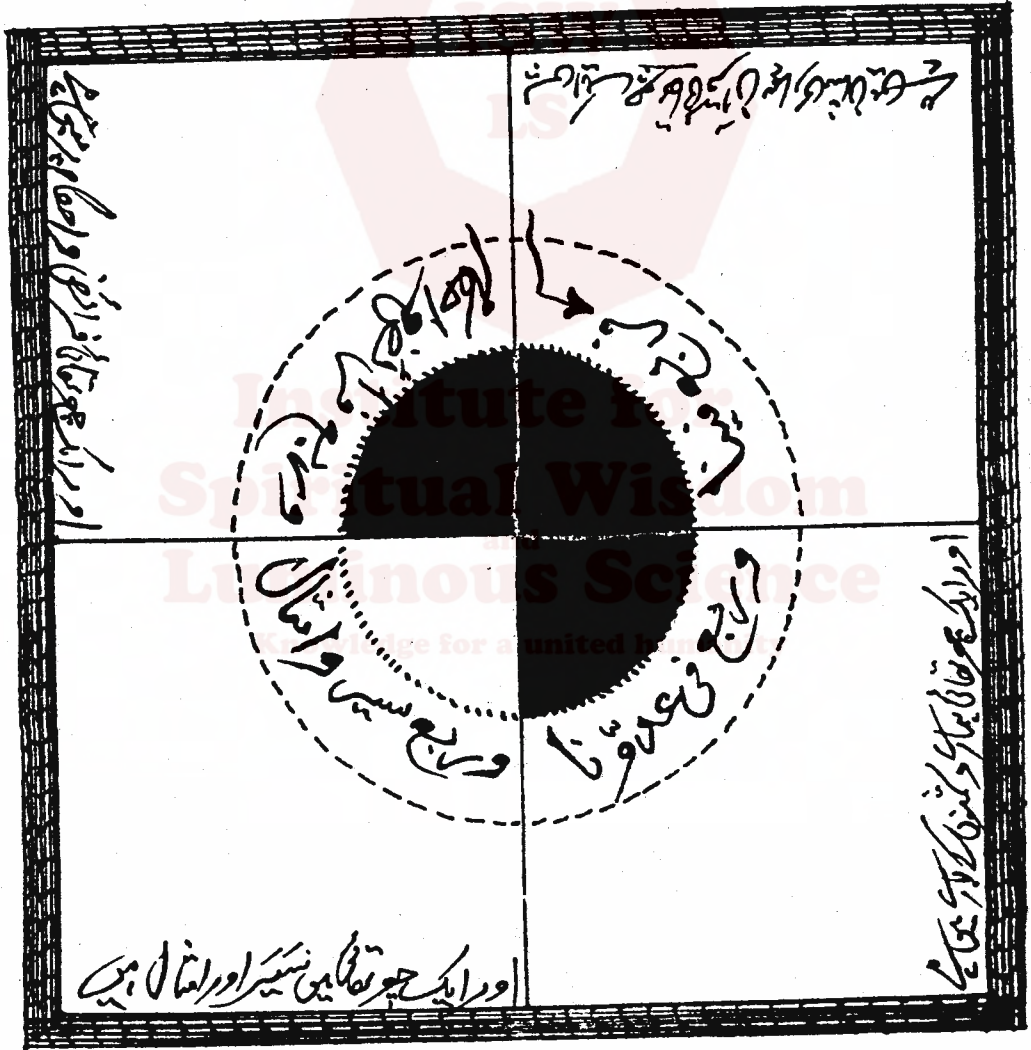

قرآن کے چاروں حصوں کی مثال

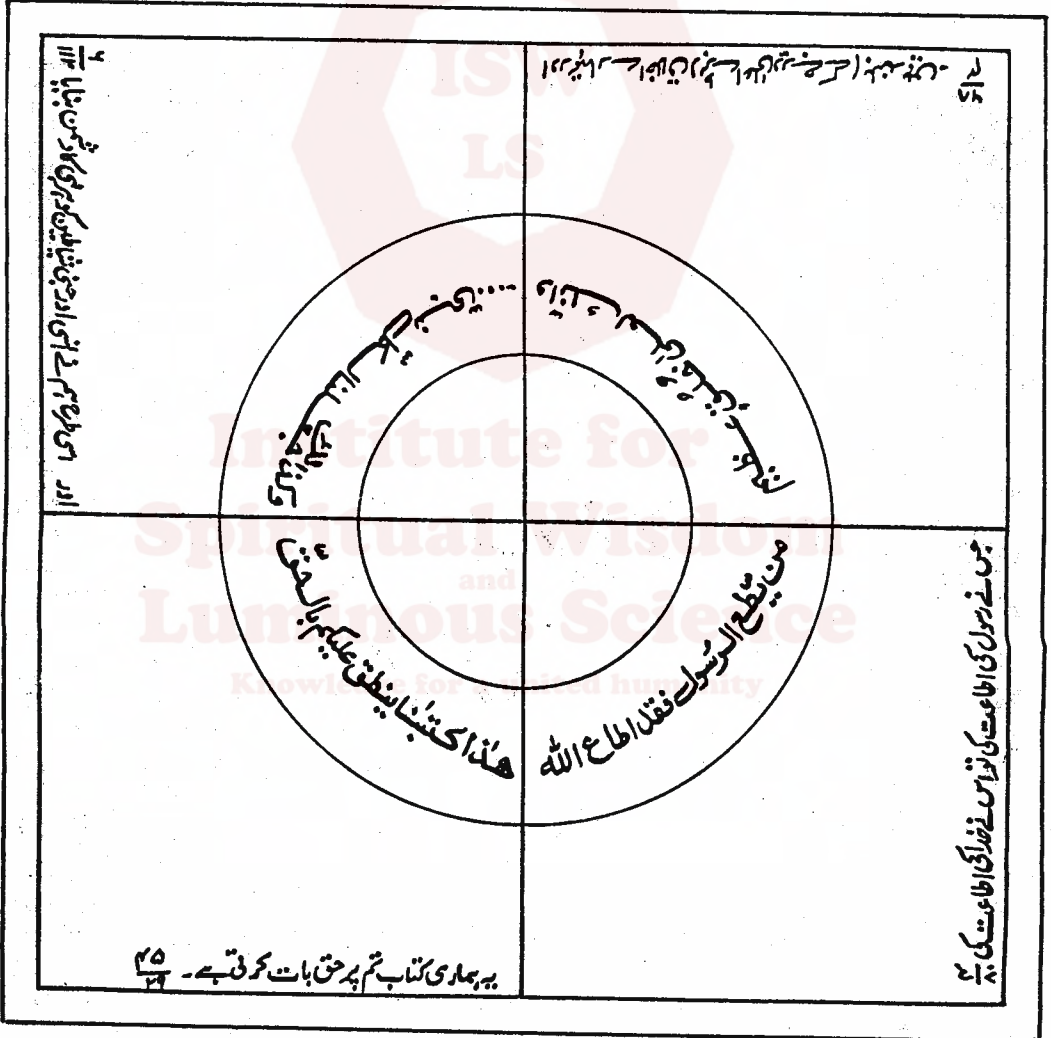

قرآن کے چاروں حصوں کی مثال سے

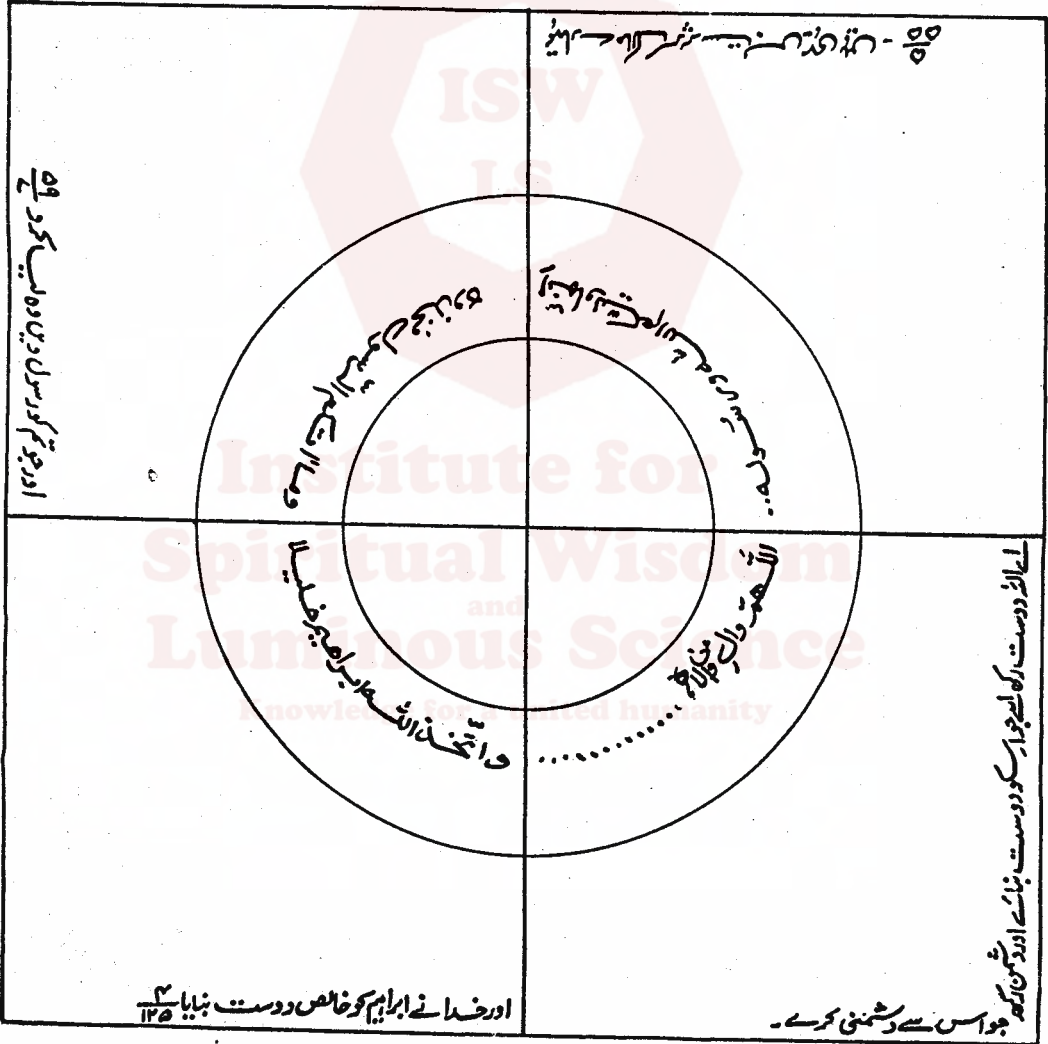

قرآن کے چاروں حصوں کی مثال ۴

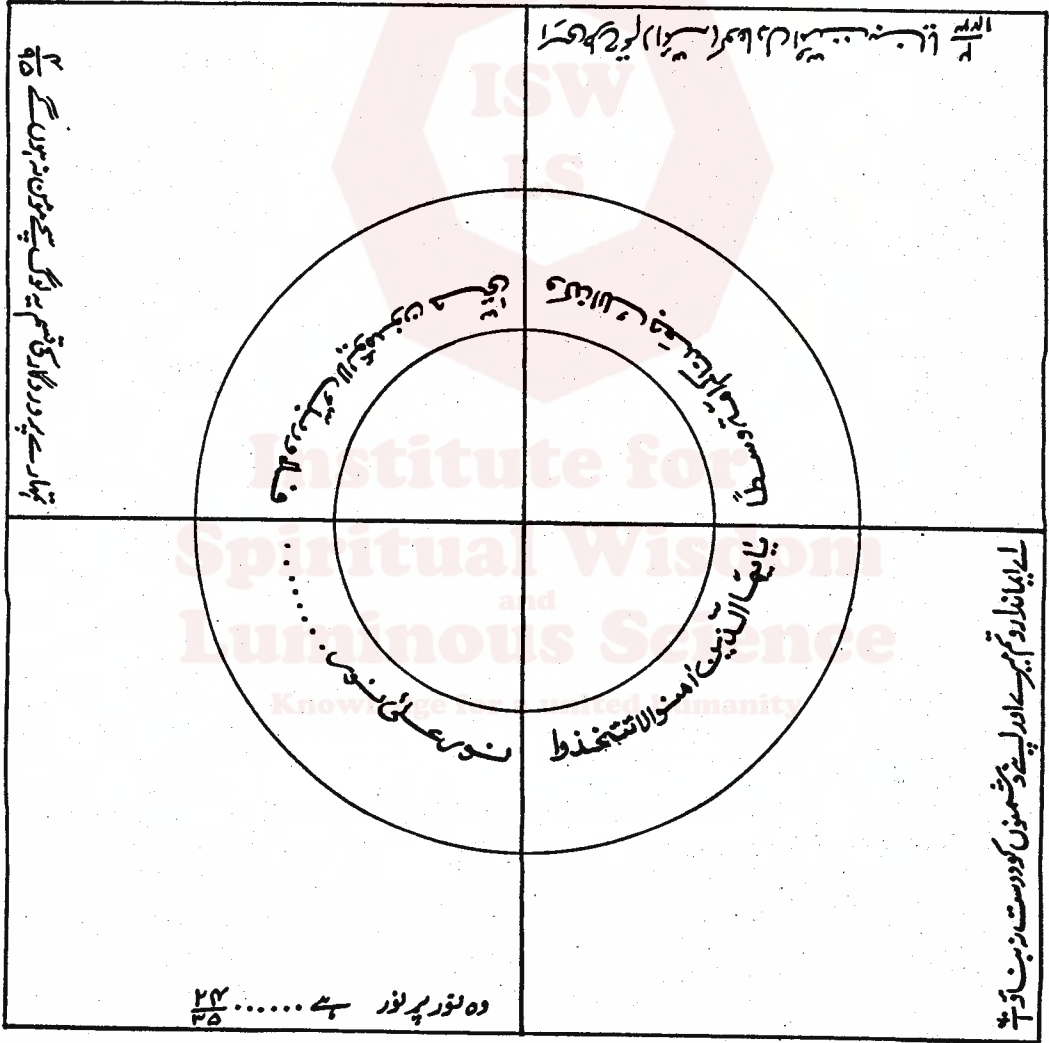

ŞIRĀT-AL-MUSTAQĪM

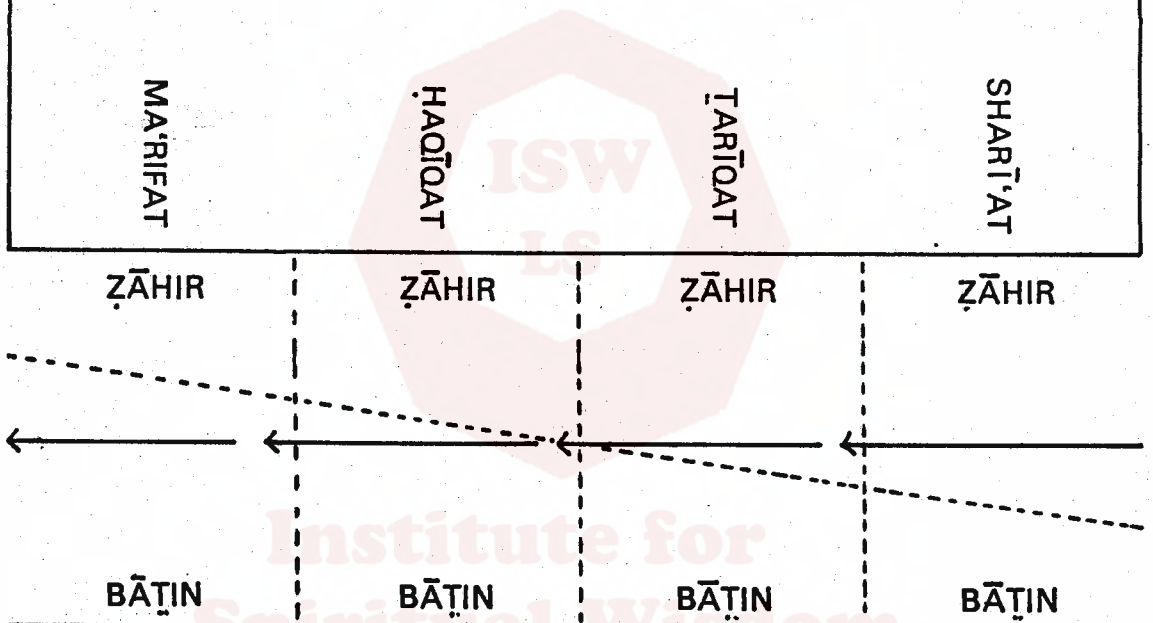

AND (HE COMMANDETH YOU, SAYING): THIS IS MY STRAIGHT PATH SO FOLLOW IT. FOLLOW NOT OTHER WAYS LEST YE BE PARTED FROM HIS WAY (6 : 153)

ONENESS OF IMAM AND 'ĀRIF.

YOUR CREATION AND YOUR RAISING (FROM THE DEAD) ARE ONLY AS (THE CREATION AND THE RAISING OF) SINGLE SOUL. LO! ALLAH IS HEARER, KNOWER (31:28)

فنا فی المرشد / الامام علیه السلام

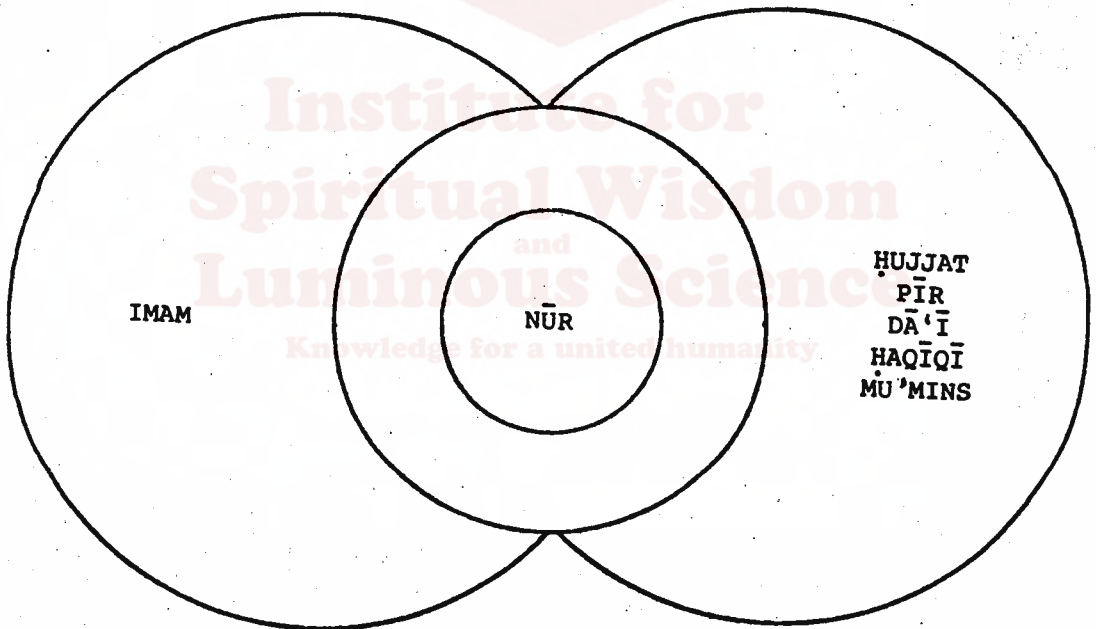

THE NOOR AND THE WORD OF ISM-I AZAM

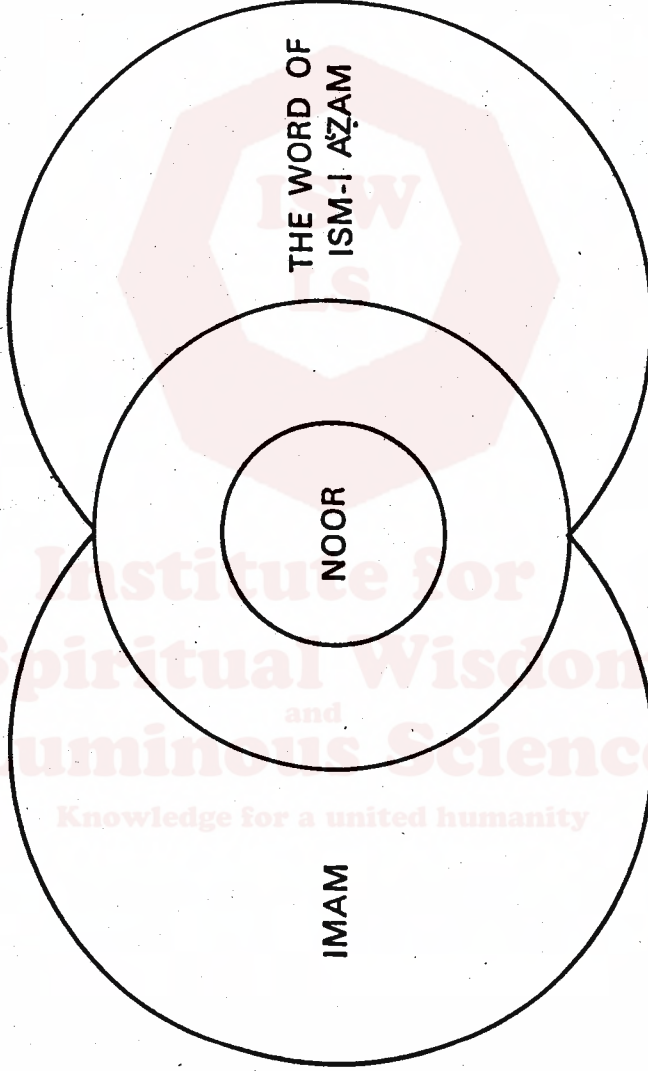

اما عمران عليه السلام فقال يا اسم اعظم بين (٤/١٦٠)

VEILS

SEVEN HUNDRED VEILS OF THE NOOR

AND IT WAS NOT (VOUCHSAFED) TO ANY MORTAL THAT ALLAH SHOULD SPEAK TO HIM UNLESS (IT BE) BY REVELATION OR FROM BEHIND A VEIL, OR (THAT) HE SENDETH A MESSENGER TO REVEAL WHAT HE WILL BY HIS LEAVE. LO! HE IS EXALTED, WISE. (42:51)

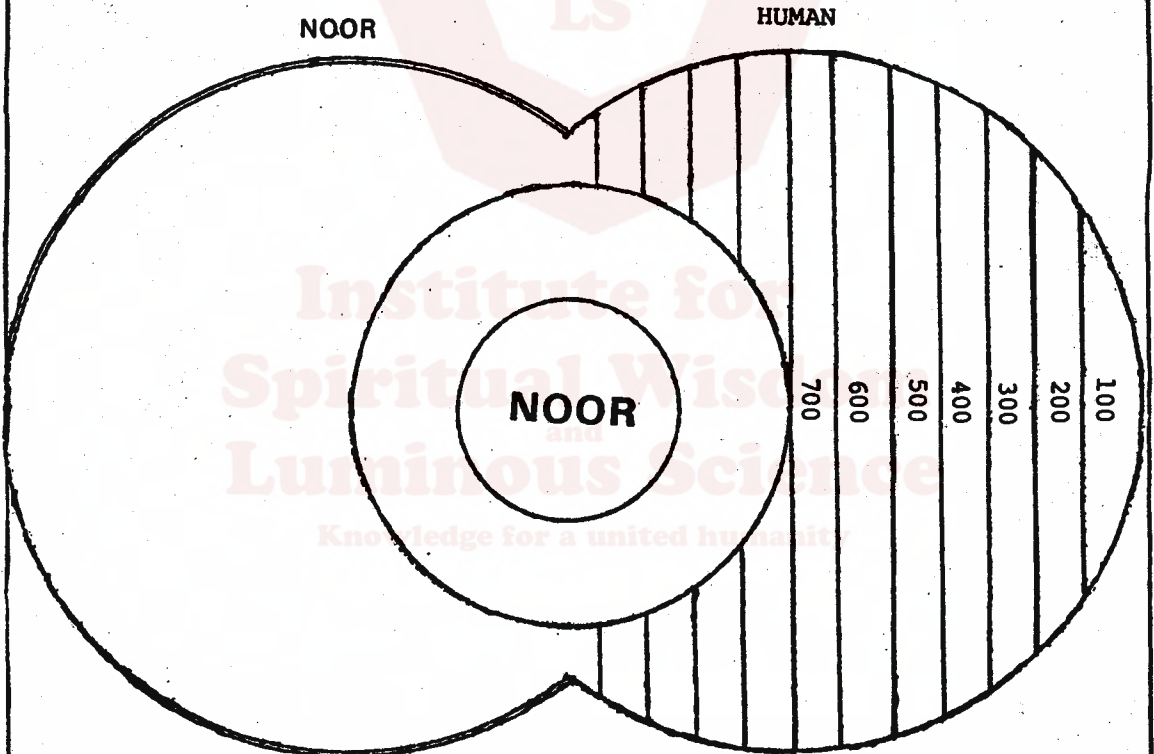

UNITY OF THE HOLY BOOK AND THE PROPHET

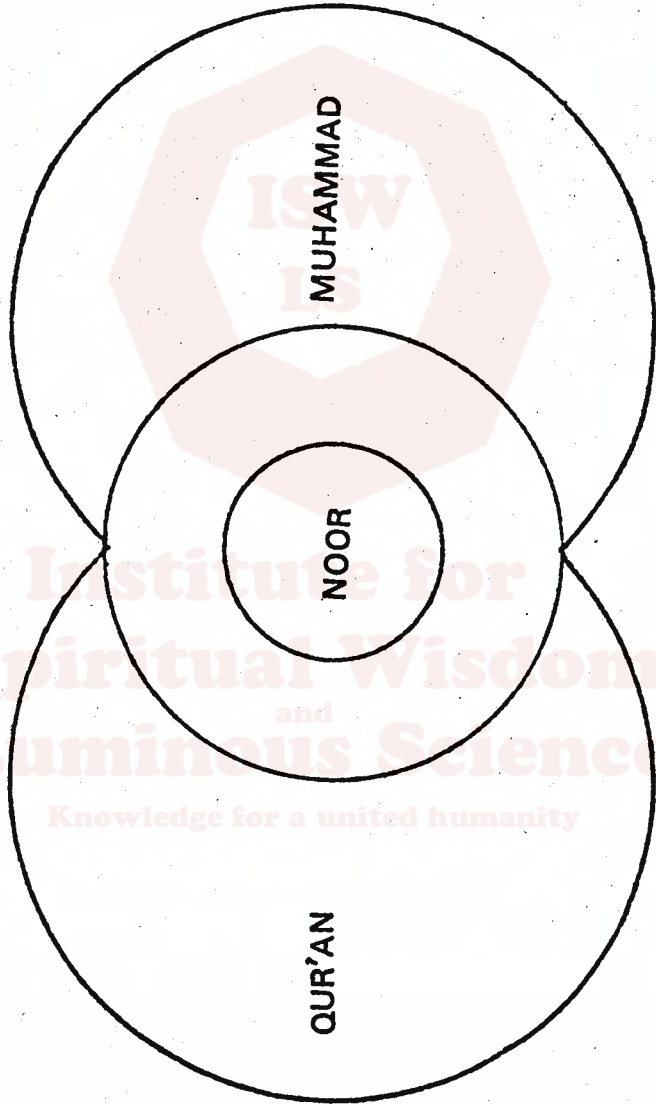

AND THUS HAVE WE INSPIRED IN THEE (MUHAMMAD) A SPIRIT OF OUR
COMMAND. THOU KNEWEST NOT WHAT THE SCRIPTURE WAS, NOR WHAT
THE FAITH. BUT WE HAVE MADE IT A LIGHT WHEREBY WE GUIDE WHOM
WE WILL OF OUR BOND MEN. (42:52)

ONENESS OF MUHAMMAD AND 'ALĪ

THEN THOSE WHO BELIEVE IN HIM (MUHAMMAD) AND HONOUR HIM,
AND FOLLOW THE NOOR WHICH IS SENT DOWN WITH HIM: THEY
ARE THE SUCCESSFUL. (7:157)

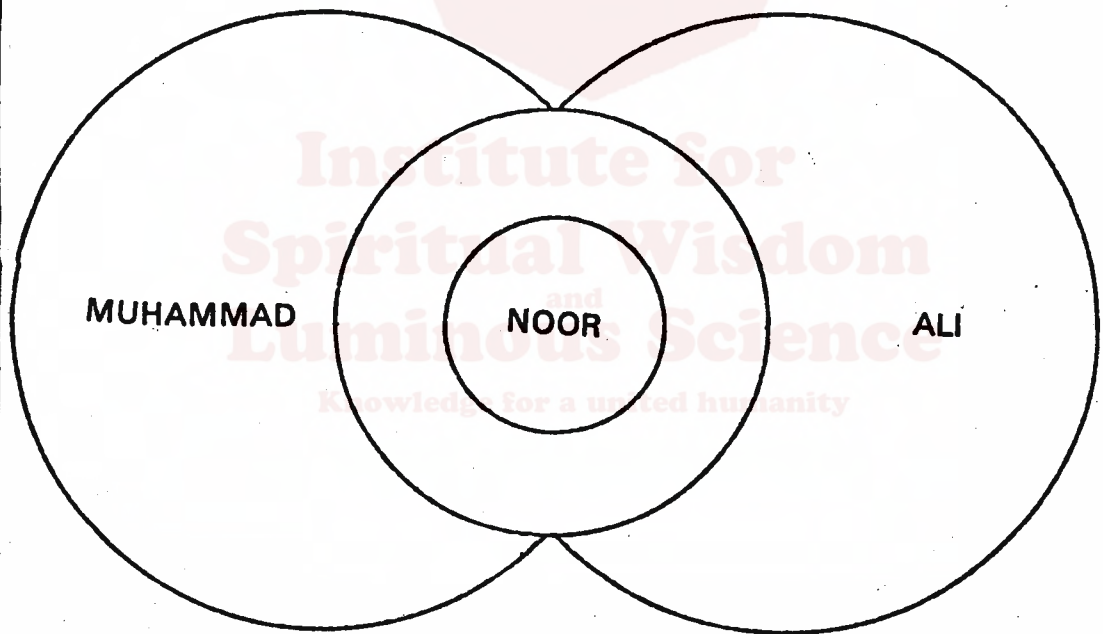

ONENESS OF QUR'ĀN AND 'ALĪ

AND LO! THAT IS A TREMENDOUS OATH, IF YE BUT KNEW, THAT (THIS) IS INDEED A NOBLE QUR'ĀN, IN A BOOK KEPT HIDDEN, WHICH NONE TOUCHETH SAVE THE PURIFIED (56; 76-79)

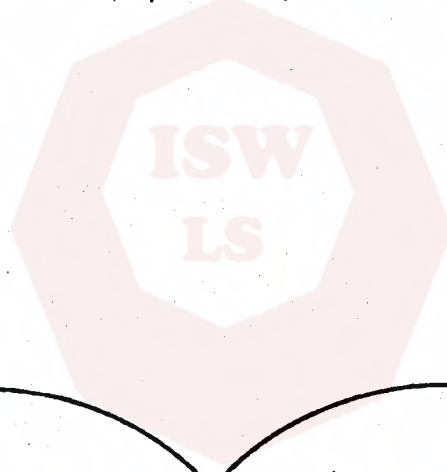

Institute for
Spiritual Wisdom
and
Luminous Science
Knowledge for a united humanity

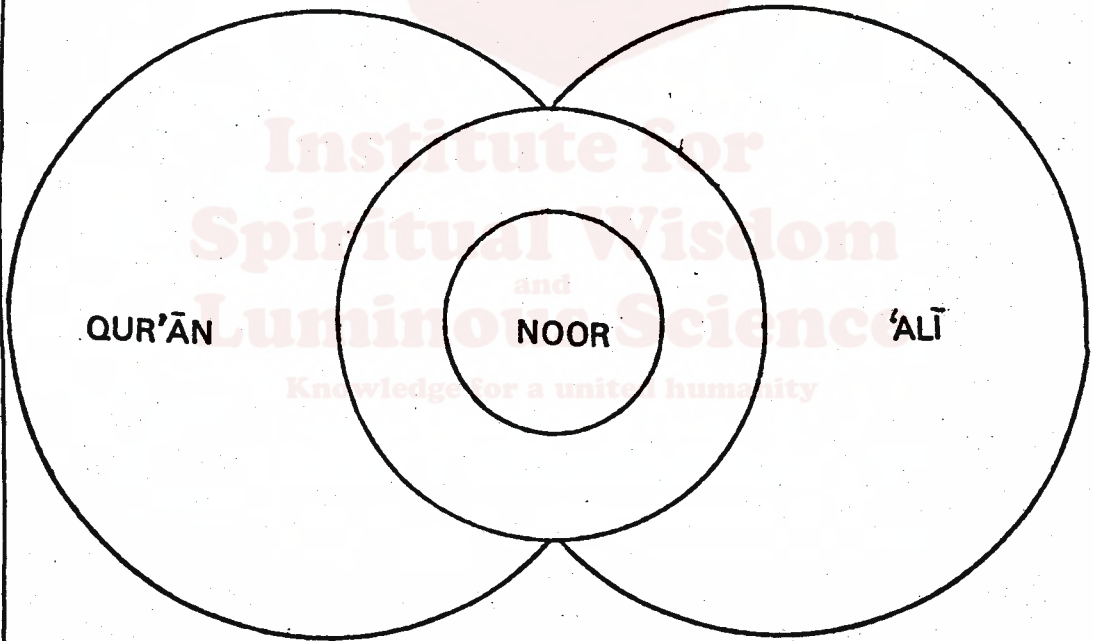

ONENESS OF 'ALI AND HĀZIR IMĀM

ALLAH IS THE LIGHT OF THE HEAVENS AND THE EARTH. THE SIMILITUDE OF HIS NOOR IS AS A NICHE WHEREIN IS A LAMP. THE LAMP IS IN A GLASS.

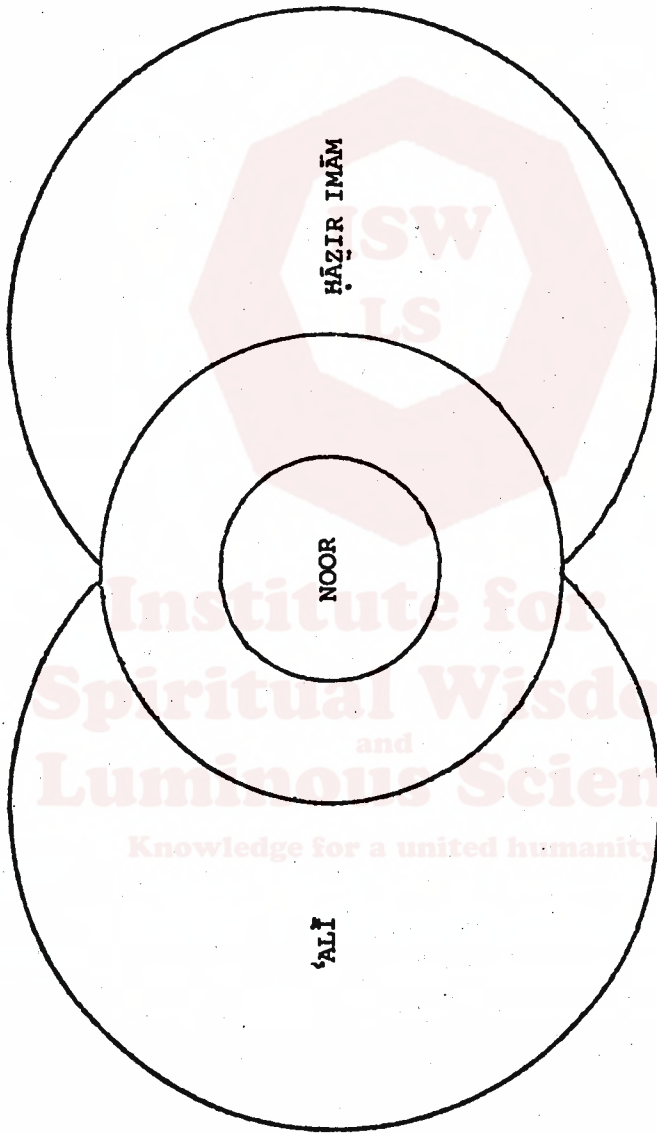

THE GLASS IS AS IT WERE A SHINING STAR. (THIS LAMP IS) KINDLES FROM A BLESSED TREE, AN OLIVE NEITHER OF THE EAST NOR OF THE WEST, WHOSE OIL WOULD ALMOST GLOW FORTH (OF ITSELF) THOUGH NO FIRE TOUCHED IT. LIGHT UPON LIGHT, ALLAH GUIDETH UNTO HIS NOOR WHOM HE WILL. AND ALLAH SPEAKETH TO MANKIND IN ALLEGORIES, FOR ALL IS KNOWER OF ALL THINGS. (24: 35)

ONENESS OF QUR'ĀN AND HĀZIR IMĀM

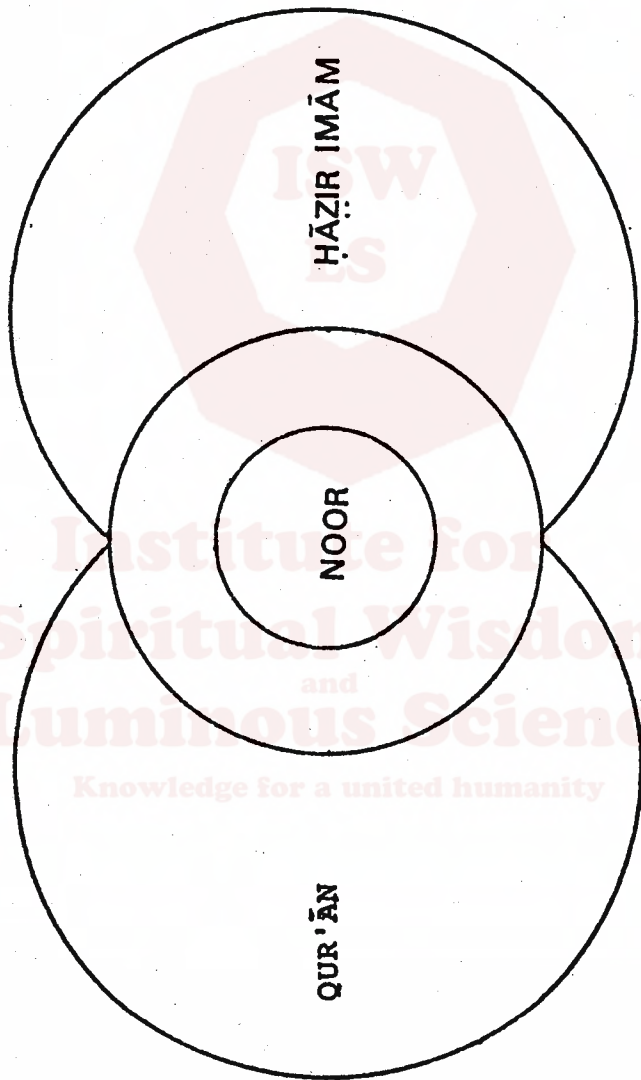

NOW HATH COME UNTO YOU NOOR FROM GOD AND A PLAIN SCRIPTURE,
WHERE-BY ALLAH GUIDETH HIM WHO SEEKETH HIS GOOD PLEASURE UNTO
PATHS OF PEACE. HE BRINGETH THEM OUT OF DARKNESS UNTO NOOR BY HIS
DECREE AND GUIDETH THEM UNTO A STRAIGHT PATH. (5: 15-16)
No. 18

ALIF. LĀM. MĪM.

In the name of Allah, the Beneficent, the Merciful.
Alif. Lam. Mim. This is the Scripture whereof there
is no doubt, a guidance unto those who ward off (evil).

LETTERS	ALM ↓ ↓ ↓	ALM ↓ ↓	ALM ↓ ↓	ALM ↓ ↓	ALM ↓ ↓	ALM ↓ ↓
TAQLĪB	ALM	AML	LAM	LMA	MAL	MLA
WORDS	ALAM	AMAL	LĀM	LIMĀ	MĀL	MALA'
MEANING	pain	hope	lām	why	wealth	chiefs
TA'WĪL (WISDOM)	DIVINE LOVE	HOPE OF DĪDĀR	RECOGNITION	QUESTION	SPIRITUAL WEALTH	A'IMMAH (Imāms)

For all these matters you should follow the Imams.

34
ALIF LĀM MĪM

الم

pronunciation	ALIF LĀM MĪM
extension	aliflammim
basic letters	+++ + + alflammim
answer	alf mi
word	Alfmi (Alfami = الغمي)
meaning	relating to the mouth=oral.
Ta'wīl	Speaking_Book (Imām)

HOLY QUR'AN AND THE IMAM

ALIF. LĀM. MĪM.

^x
ALIF. LAM. MIM.

+ + +
ALF. LAM. MIM.

↓ ↓ ↓
LAI

<p style="text-align: center;">ḤURŪF-I WASTĪ (Central-Letters)</p>	<p>LAI</p>
<p style="text-align: center;">TAQLĪB</p>	<p>LAI LIA ALI AIL ILA IAL</p>
<p style="text-align: center;">Words</p>	<p>LAI LIA ALI AIL ILA IAL</p>
<p style="text-align: center;">Answer</p>	<p>ALI</p>
<p style="text-align: center;">TĀWĪL (WISDOM)</p>	<p style="text-align: center;">IT MEANS THAT MAWLĀ ALĪ IS AL-KITĀB (OF ALIF. LĀM. MĪM.)-IN WHICH THERE IS NO DOUBT.</p> <p style="text-align: right; font-style: italic;">No. 19-C</p>

ALIF. LĀM. MĪM

A + L + M

1 + 30 + 40 = 71 = 7 + 1 = 8

The answer is 8.

Ḥ U D Ū D - I D Ī N	F O R M U L A	
MUSTAJĪB	1	<p>Note: It means that the Imam is the Divine Secret of ALIF. LĀM. MĪM., and he is ZĀLIK AL-KITĀB (the Speaking Book) in which there is no doubt.</p>
MĀZŪN-I ASGHAR	2	
MĀZŪN-I AKBAR	3	
DĀ'Ī-I MAKFŪF	4	
DĀ'Ī-I MUṬLAQ	5	
HUJJAT	6	
BĀB	7	
IMĀM	8	
ASĀS	9	
NĀTIQ	10	
NAFS-I KULL	100	
'AQL-I KULL	1000	

37
AND ALL THINGS WE HAVE VESTED
IN A MANIFESTING IMAM (36:12)

AN IMAM FOR MANKIND (2:124)

IMAMS WHO GUIDE (21: 73)

MEN WITH THEIR IMAM (17: 71)

AN IMAM AND A MERCY (11: 17)

AND MAKE US IMAMS (25: 74)

AND TO MAKE THEM IMAMS (28: 5)

AN IMAM AND A MERCY. (46: 12)

IMĀM-I MUBĪN (15: 79)

AMONG THEM IMAMS (32: 24)

حدیثِ مماثلتِ ہارونی کی روشنی میں دیکھا جائے :-

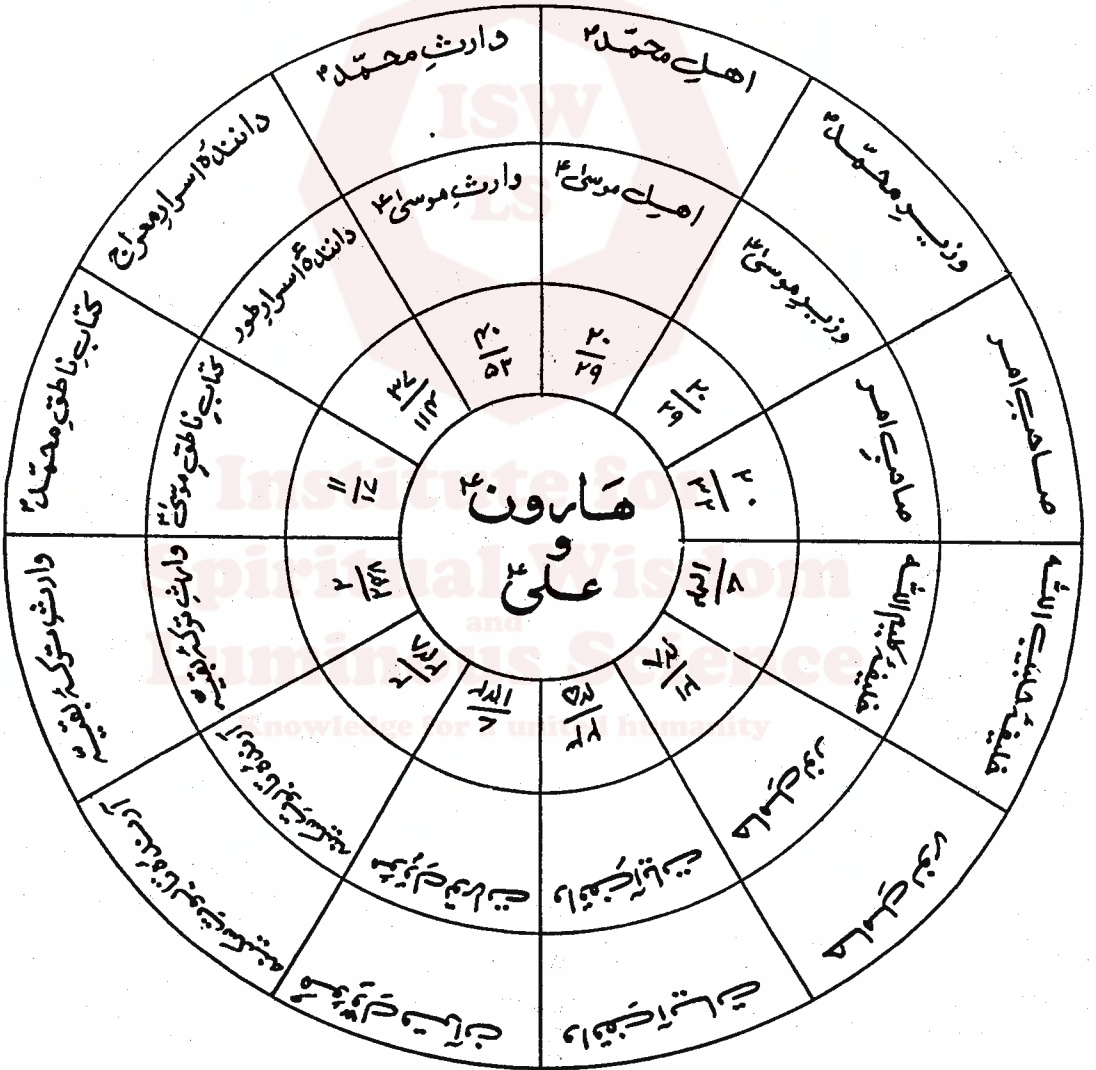

پنجتن پاک

39

اہل بیت ۳۳ اہل ذکر ۱۶ اہل قرآن ۲۱ محمد وآل محمد ۳۱ آل ابراہیم ۲۴
 آل عمران ۳ اولوالامر ۲ اولیاء اللہ ۱۰ اہل کوثر ۱ اہل بیت نور ۲۲
 ۳۶

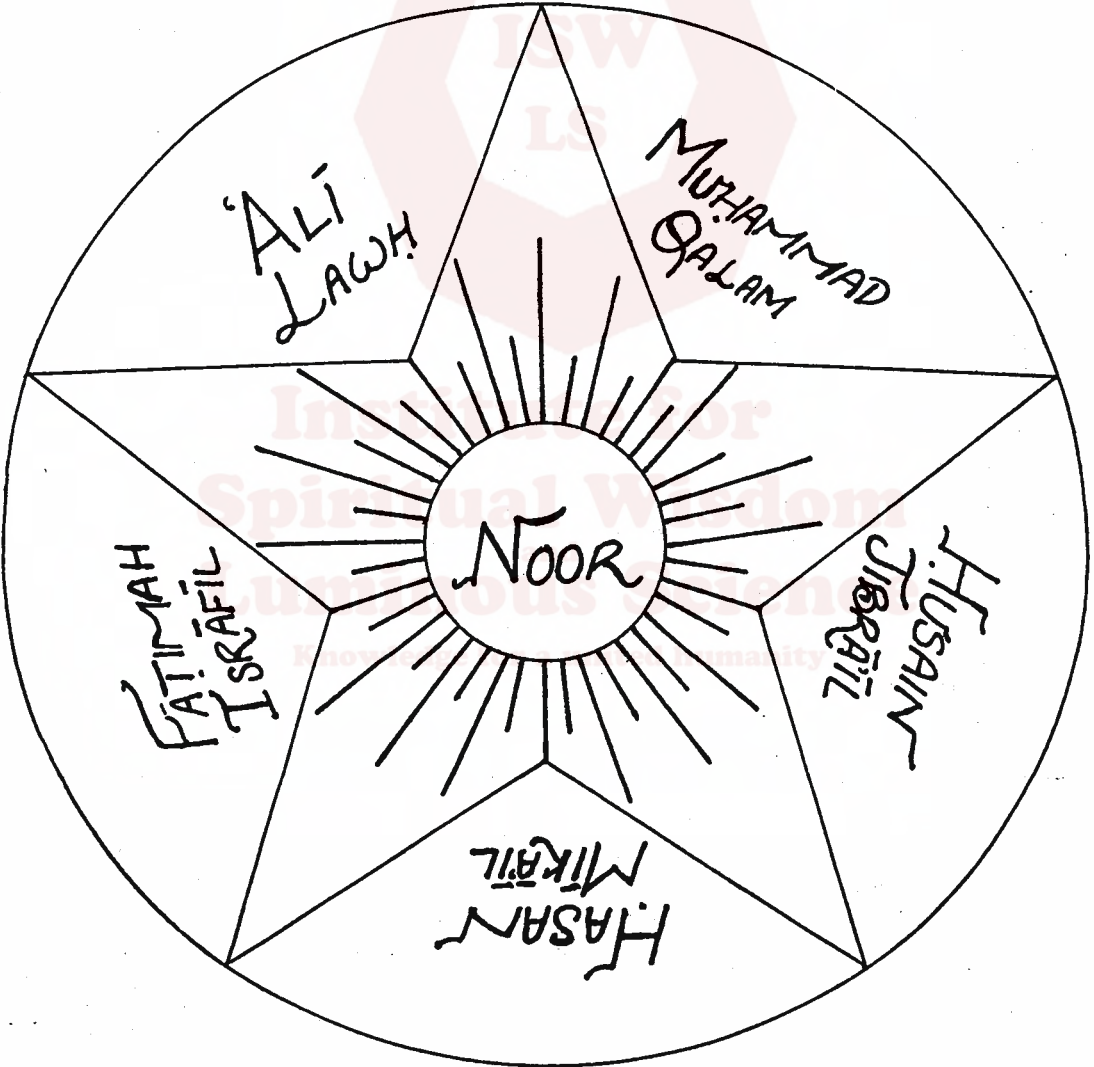

THE ROPE OF ALLAH

AND HOLD FAST, ALL OF YOU TOGETHER, TO THE ROPE OF ALLAH AND DO NOT SEPARATE. AND REMEMBER ALLAH'S FAVOUR UNTO YOU: HOW YE WERE ENEMIES AND HE MADE FRIENDSHIP BETWEEN YOUR HEARTS SO THAT YE BECAME AS BROTHERS BY HIS GRACE. (3 : 103)

FIRST CYCLE: ADAM PROCLAIMER (NĀTIQ)	ABEL: 1st REGENT (WAṢĪ) SETH: 2nd REGENT (WAṢĪ)
SECOND CYCLE: NOAH PROCLAIMER (NĀTIQ)	SHEM: REGENT (WAṢĪ)
THIRD CYCLE: ABRAHAM PROCLAIMER (NĀTIQ)	ISHMAEL: REGENT (WAṢĪ)
FOURTH CYCLE: MOSES PROCLAIMER (NĀTIQ)	AARON: REGENT (WAṢĪ)
FIFTH CYCLE: JESUS PROCLAIMER (NĀTIQ)	SIMON: (SHAM'ŪN) REGENT (WAṢĪ)
SIXTH CYCLE: MUḤAMMAD PROCLAIMER (NĀTIQ)	'ALĪ: REGENT (WAṢĪ)
SEVENTH CYCLE: RESURRECTOR (AL-QĀ'IM)	A'IMMAH (IMAMS)

NOTE: THE ROPE OF ALLAH IS THE LINEAGE OF PROPHETS AND IMAMS, SO THE ABOVE MENTIONED AYAT IN ITS ALLEGORICAL MEANING SAYS THAT AFTER PROPHET MUHAMMAD THERE IS ALWAYS NECESSARILY PRESENT THE IMAM OF THE TIME IN THIS WORLD.

THE ROPE OF ALLAH

AND HOLD FAST, ALL OF YOU TOGETHER, TO THE ROPE OF ALLAH AND DO NOT SEPARATE. AND REMEMBER ALLAH'S FAVOUR UNTO YOU: HOW YE WERE ENEMIES AND HE MADE FRIENDSHIP BETWEEN YOUR HEARTS SO THAT YE BECAME AS BROTHERS BY HIS GRACE. (3 : 103)

- | | |
|--------------------------------|-------------------------------|
| (1) 'ALĪ | (25) JALĀL AL-DĪN (HASAN) |
| (2) HUSAIN | (26) 'ALĀ'U DĪN (MUHAMMAD) |
| (3) ZAYN AL-'ĀBIDĪN | (27) RUKN AL-DĪN KHURSHĀH |
| (4) MUHAMMAD AL-BĀQIR | (28) SHAHM AL-DĪN (MUHAMMAD) |
| (5) JA'FAR AL-ŞĀDIQ | (29) QĀSIM SHĀH |
| (6) ISMĀ'IL | (30) ISLĀM SHĀH |
| (7) MUHAMMAD B. ISMĀ'IL | (31) MUHAMMAD B. ISLĀM SHĀH |
| (8) WAFĪ AHMAD ('ABDULLĀH) | (32) MUSTANŞIR BI ALLĀH |
| (9) TAQĪ MUHAMMAD | (33) 'ABD AL-SALĀM (MUHAMMAD) |
| (10) RADĪ-U DIN 'ABDULLĀH | (34) GHARĪB MIRZĀ ('ABBĀS) |
| (11) AL-MAHDĪ ('UBAYD-U-ALLĀH) | (35) ABŪ AL-DHIR 'ALĪ |
| (12) AL-QĀ'IM (MUHAMMAD) | (36) MURĀD MIRZĀ |
| (13) AL-MANŞŪR (ISMĀ'IL) | (37) DHŪ AL-FIQĀR 'ALĪ |
| (14) AL-MU'IZZ (MA'D) | (38) NŪR AL-DĪN 'ALĪ |
| (15) AL-'AZĪZ (NIZĀR) | (39) KHALĪL ALLĀH 'ALĪ |
| (16) AL-HĀKIM BI AMR ALLĀH | (40) NIZĀR II |
| (17) AL-ZĀHIR ('ALĪ) | (41) SAYYID 'ALĪ (ISMĀ'IL) |
| (18) AL-MUSTANSIR BI ALLĀH | (42) HASAN 'ALĪ |
| (19) NIZĀR | (43) QĀSIM 'ALĪ |
| (20) HĀDĪ ('ALI) | (44) ABŪ AL-ḤASAN 'ALĪ |
| (21) MUHTADĪ (MUHAMMAD) | (45) KHALĪL ALLĀH 'ALĪ |
| (22) QĀHIR | (46) HASAN 'ALĪ SHĀH |
| (23) 'ALĀ DHIKRI AL-SALĀM | (47) 'ALĪ SHĀH |
| (24) A'Ā MUHAMMAD | (48) SULTĀN MUHAMMAD SHĀH |

(49) SHĀH KARĪM AL-HUSAINĪ

HĀZIR IMĀM

No. 23(B)

'ALĪ IS THE GATE OF THE HOLY QUR'ĀN.

BĀ'-BAIT (HOUSE)

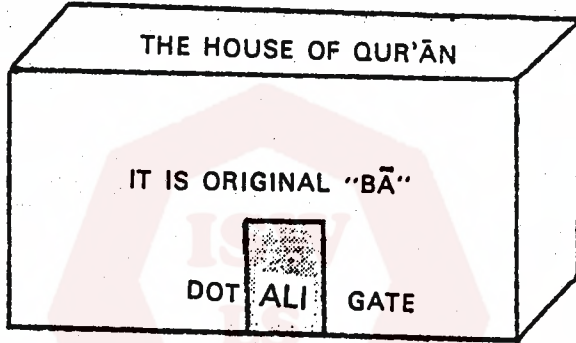

BĀ'-BAIT (HOUSE)

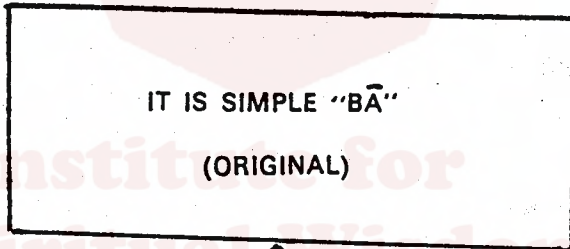

IT IS MODERN "BĀ"

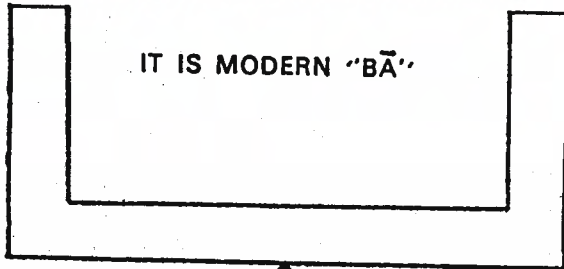

' I AM THE CITY OF KNOWLEDGE AND ALI IS ITS GATE,' (HADĪTH)
 ' I AM THE HOUSE OF WISDOM AND ALI IS ITS GATE,' (HADĪTH)
 ' I AM THE DOT OF "BĀ" IN BISMILLĀH' (KALĀM-I NAWILĀ 'ALĪ)

اور یہ کوئی بھلی بات نہیں ہے کہ تمہوں میں کچھ لوگ سے یہاں تک (اگر اللہ نیکو ہی اس شخص کی ہے جو ہمیں یہ علم دے گا) اور تمہوں میں (اللہ تعالیٰ ان کے دروازوں سے آؤں گا)

آسمانی وراثت I

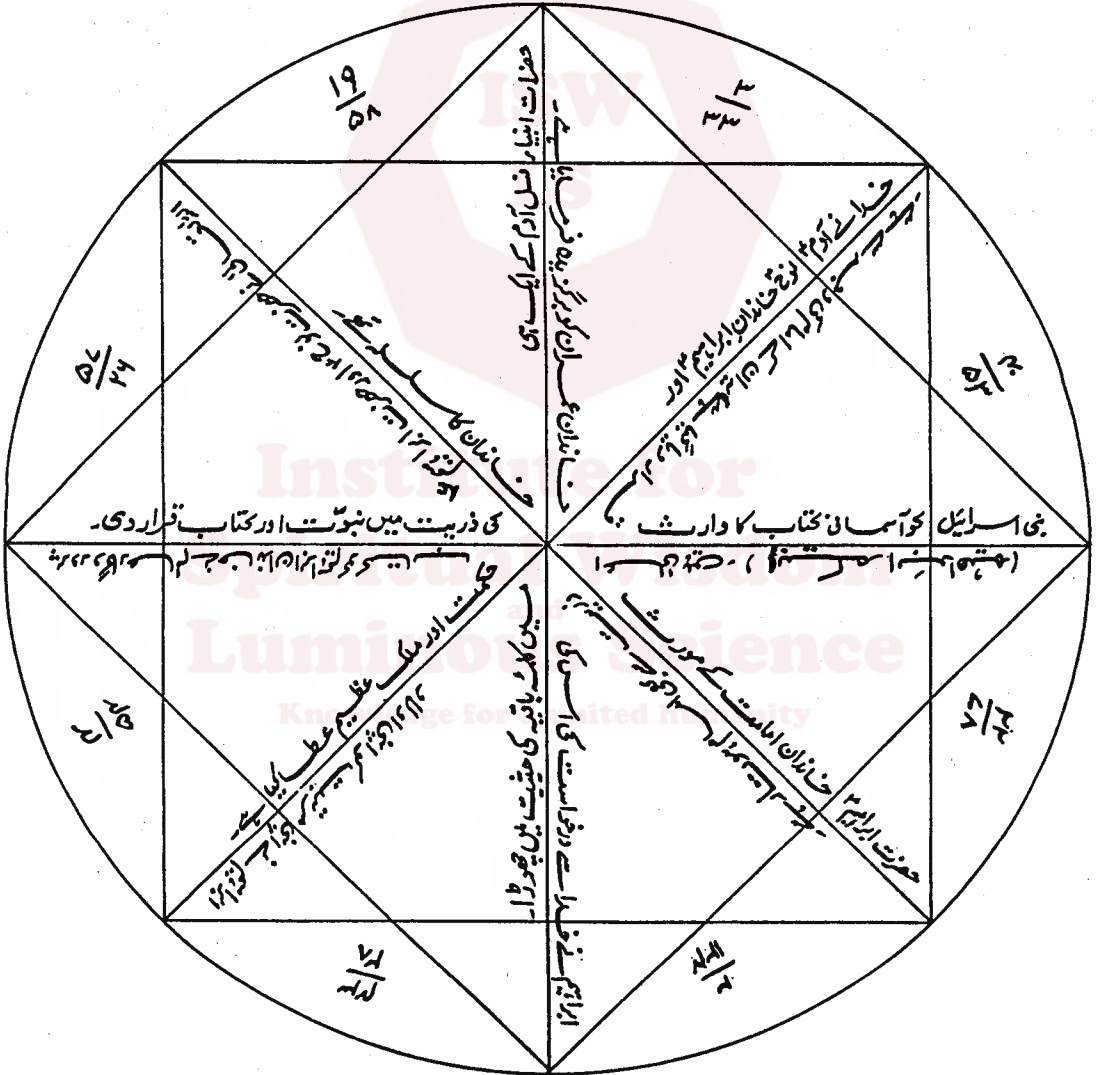

**FOUR STAGES OF ISLAM, SHOWING
THE GUIDING-CENTRE OF THE NOOR IN**

1ST STAGE

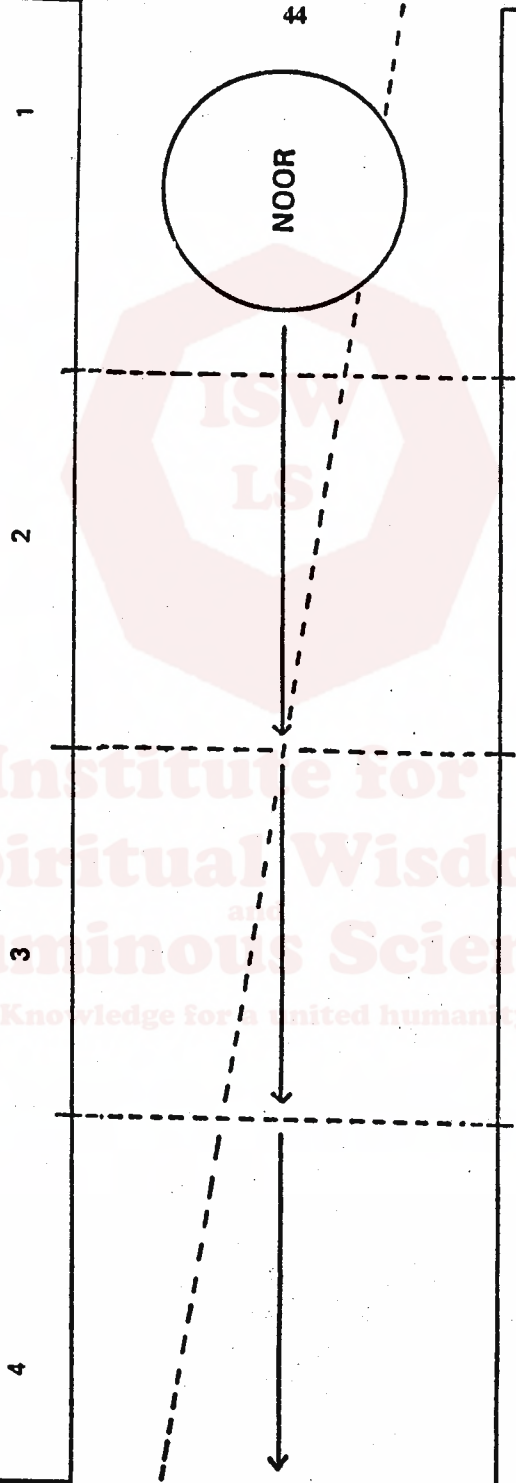

MA'RIFAT

HAQIQAT

TARIQAT

SHARI'AT

NOOR

4

3

2

1

(ALLAH) SAID: "THIS IS A WAY THAT LEADS STRAIGHT TO ME" (15:41)

**FOUR STAGES OF ISLAM, SHOWING
THE GUIDING-CENTRE OF THE NOOR IN**

2ND STAGE

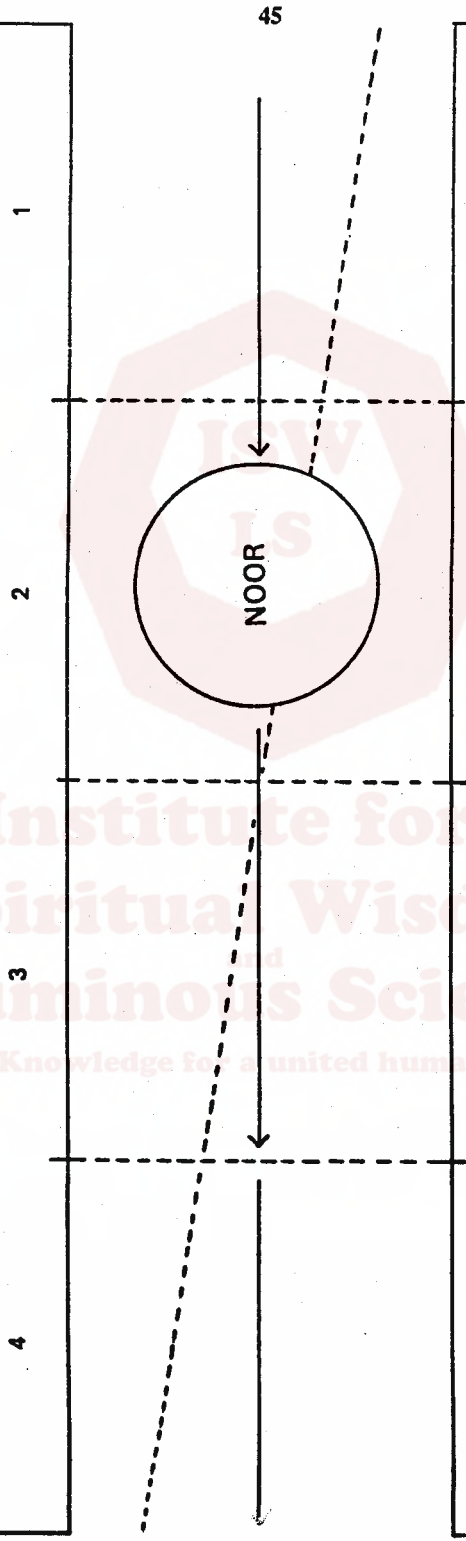

MARI'FAT

HAQIQAT

TARIQAT

SHARI'AT

VERILY, THIS IS MY WAY, LEADING STRAIGHT, FOLLOW IT (6:15)

No. 27-B

**FOUR STAGES OF ISLAM, SHOWING
THE GUIDING-CENTRE OF THE NOOR IN**

3RD STAGE

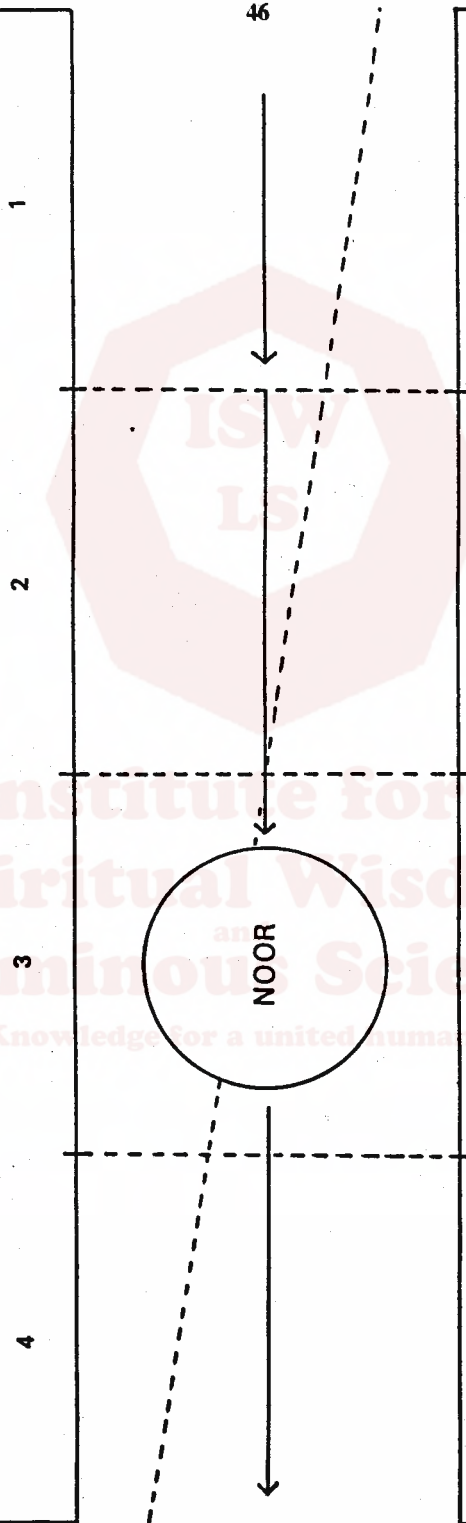

MA'RIFAT

HAQIQAT

TARIQAT

SHARI'AT

SO FOLLOW ME: I WILL GUIDE THEE ON A WAY THAT IS EVEN
AND STRAIGHT (19:43)

**FOUR STAGES OF ISLAM. SHOWING
THE GUIDING-CENTRE OF THE NOOR IN**

4TH STAGE

4

3

2

1

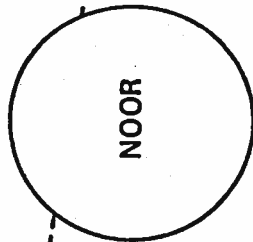

NOOR

47

MA'RIFAT

HAQIQAT

TARIQAT

SHARI'AT

HE SAID: "I WILL GO TO MY LORD! HE WILL SURELY GUIDE ME" (37 : 99)

No. 27 - D

**FOUR STAGES OF ISLAM,
SHOWING THE GUIDING-CENTRE OF THE
NOOR IN THE HOUSE OF WISDOM**

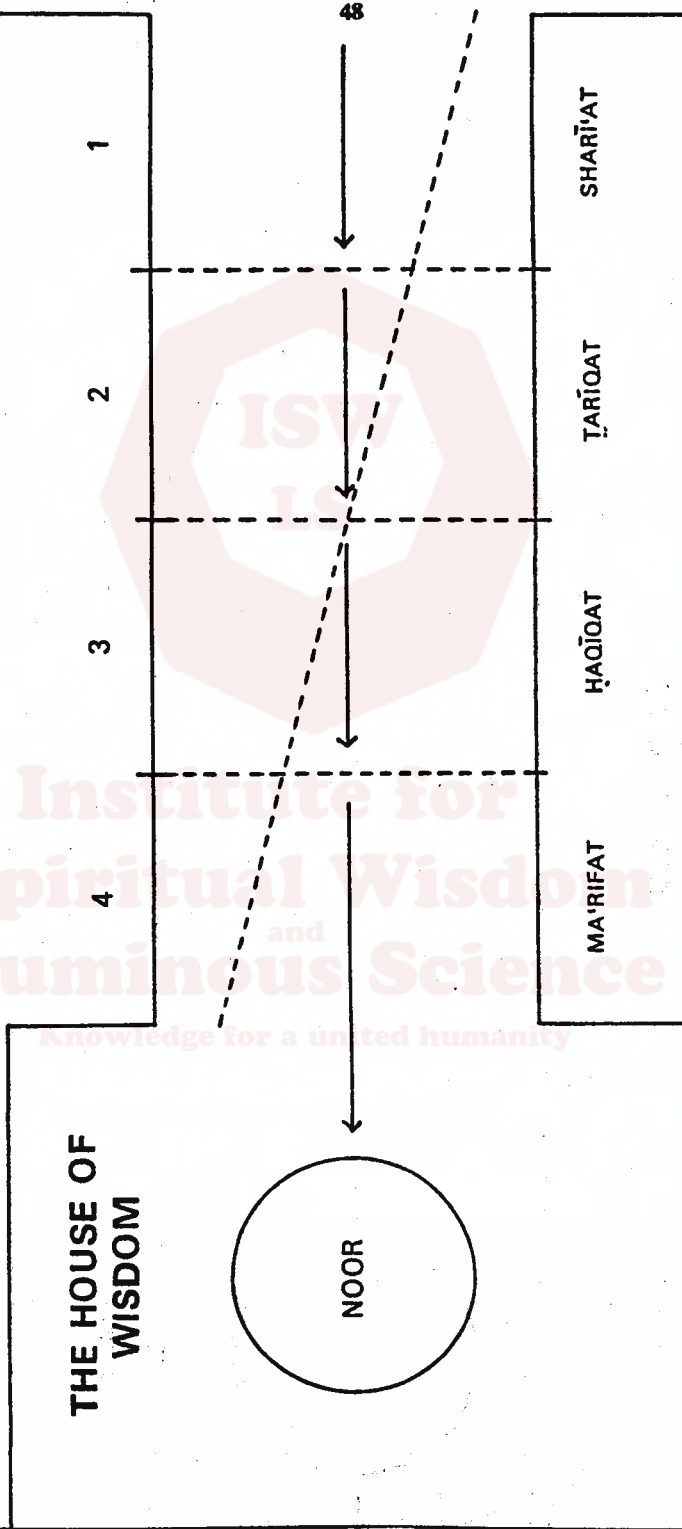

HE WILL PROVIDE FOR YOU A LIGHT BY WHICH YE SHALL WALK (57 : 28)

ALL THINGS

WA KULLA SHAI-İN AŞŞAINĀHU FĪ İMĀMIN MUBĪN (36:12)

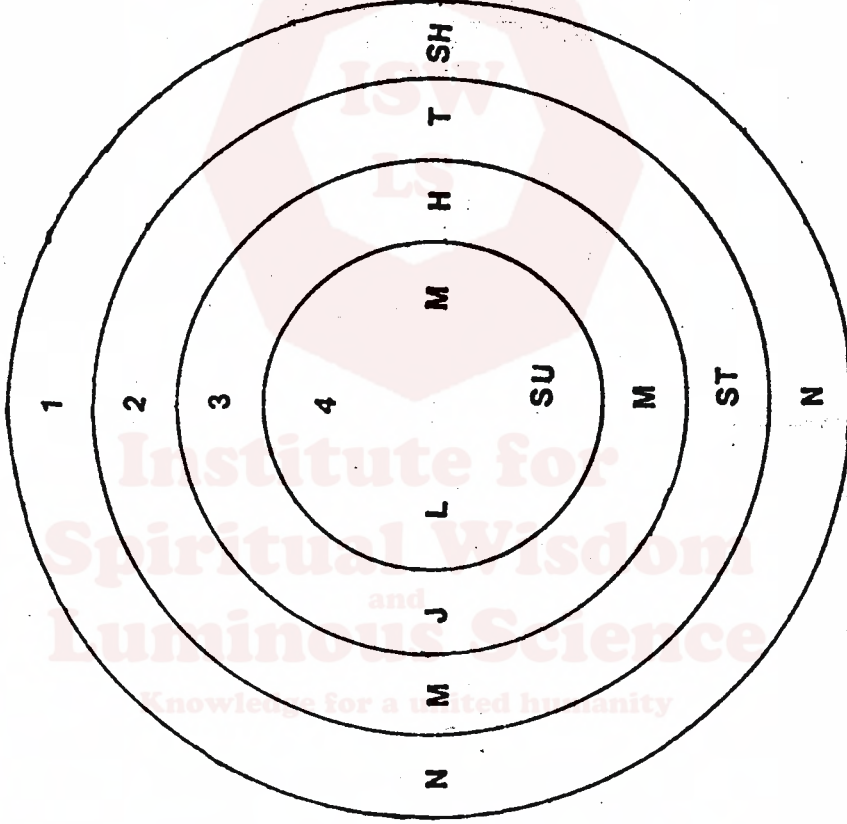

- 1. NĀSOOT
- 2. MALAKOOT
- 3. JABROOT
- 4. LĀHOOT

- 1. SHAKĪ'AT
- 2. İBĀRĪQAT
- 3. HAQĪQAT
- 4. MA'RIFAT

- 1. NIGHT
- 2. LIGHT OF STARS
- 3. LIGHT OF MOON
- 4. LIGHT OF SUN

SATAN'S MISGUIDING

HOW TO SEEK REFUGE

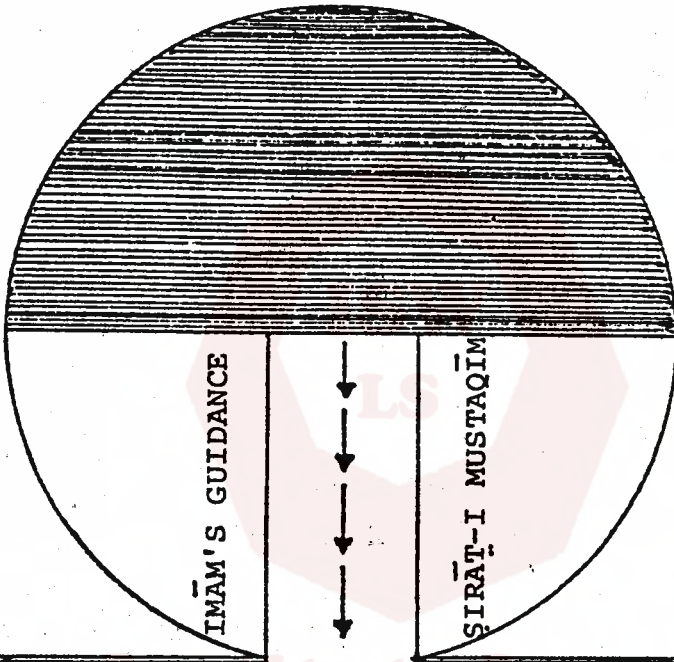

THE HOUSE OF ALLAH

THE HOUSE OF WISDOM

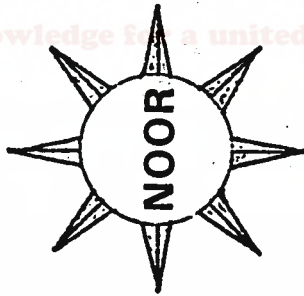

THE CITY OF SECURITY

THE CITY OF KNOWLEDGE
(THE PROPHET MUHAMMAD)

IMAM 'ALI IS THE GATE
(HAZIR IMAM)

NOTE: THIS DIAGRAM CAN HELP YOU TO UNDERSTAND THE WISDOM (TAWIL) OF EVERY AYAT FROM 6666 AYATS OF THE HOLY QUR'AN.

No. 29

COMPLETE OBEDIENCE

O YE WHO BELIEVE! OBEY ALLAH, AND OBEY MESSENGER AND THOSE OF YOU WHO ARE IN (DIVINE) AUTHORITY (4:59)

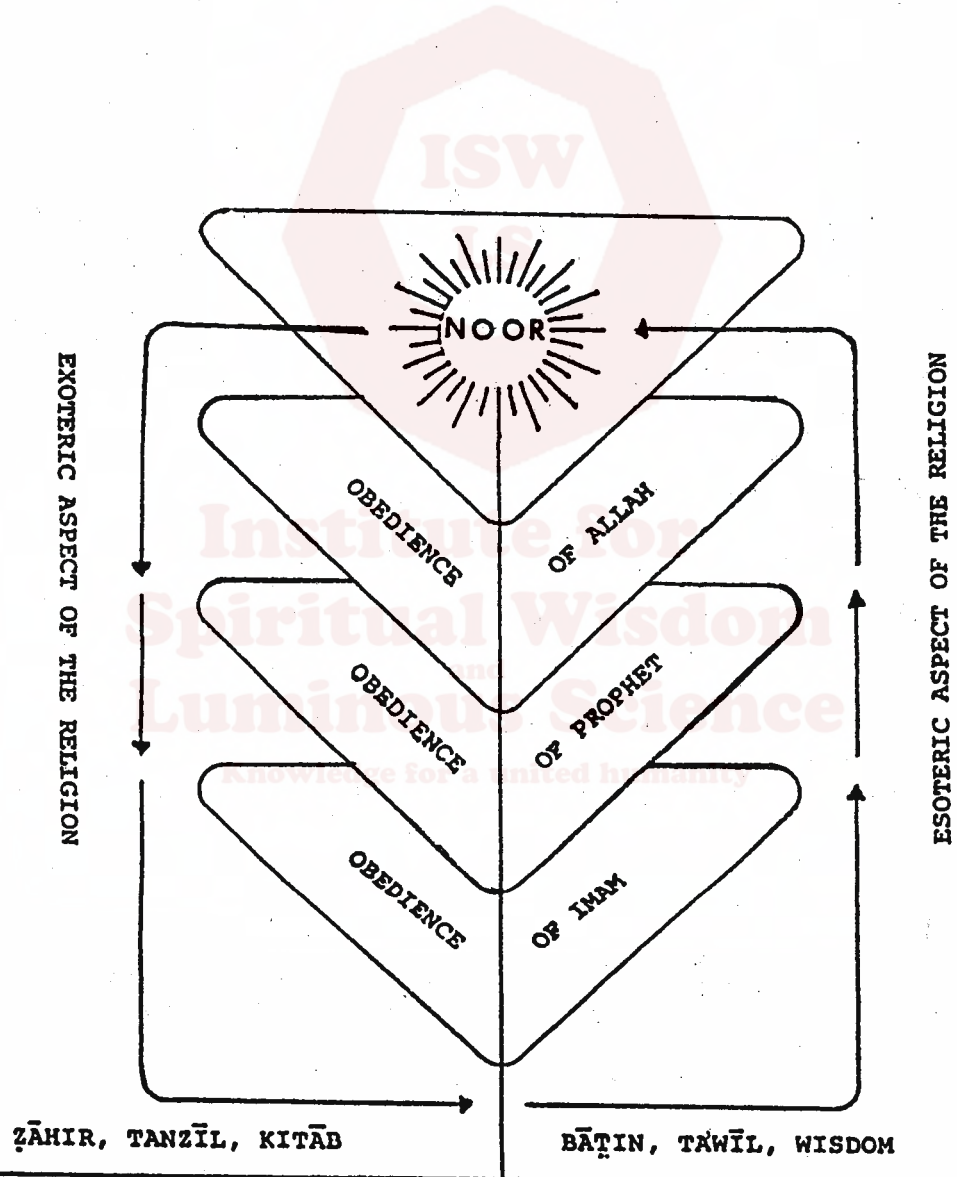

100 NAMES

AND LIVING ISM-A'ZAM (NOOR) OF GOD

ALLAH'S ARE THE FAIREST NAMES. INVOKE HIM BY THEM. AND LEAVE
THE COMPANY OF THOSE WHO BLASPHEME HIS NAMES (7:180)

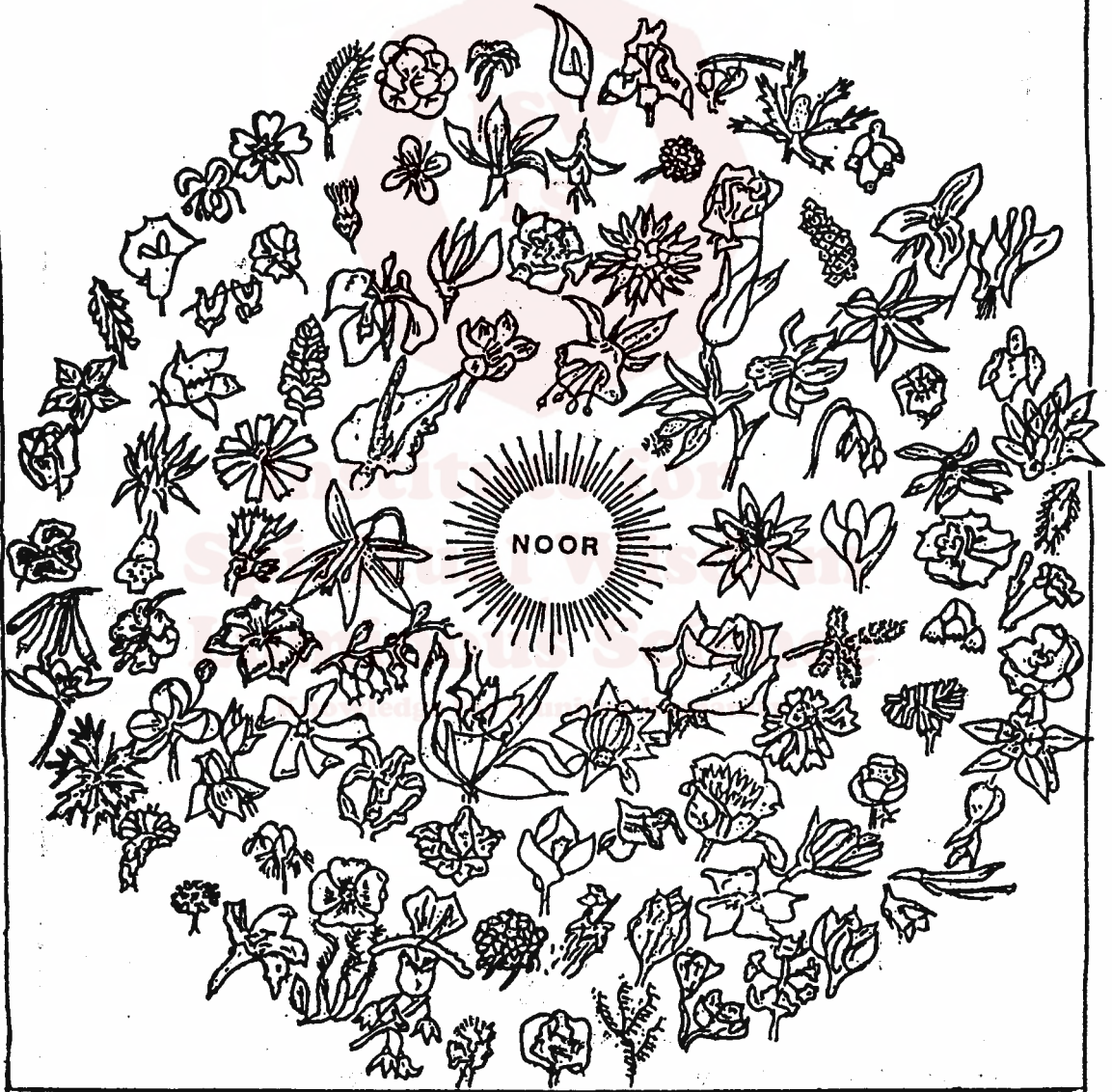

BY HEAVEN FULL OF PATHS (51:)

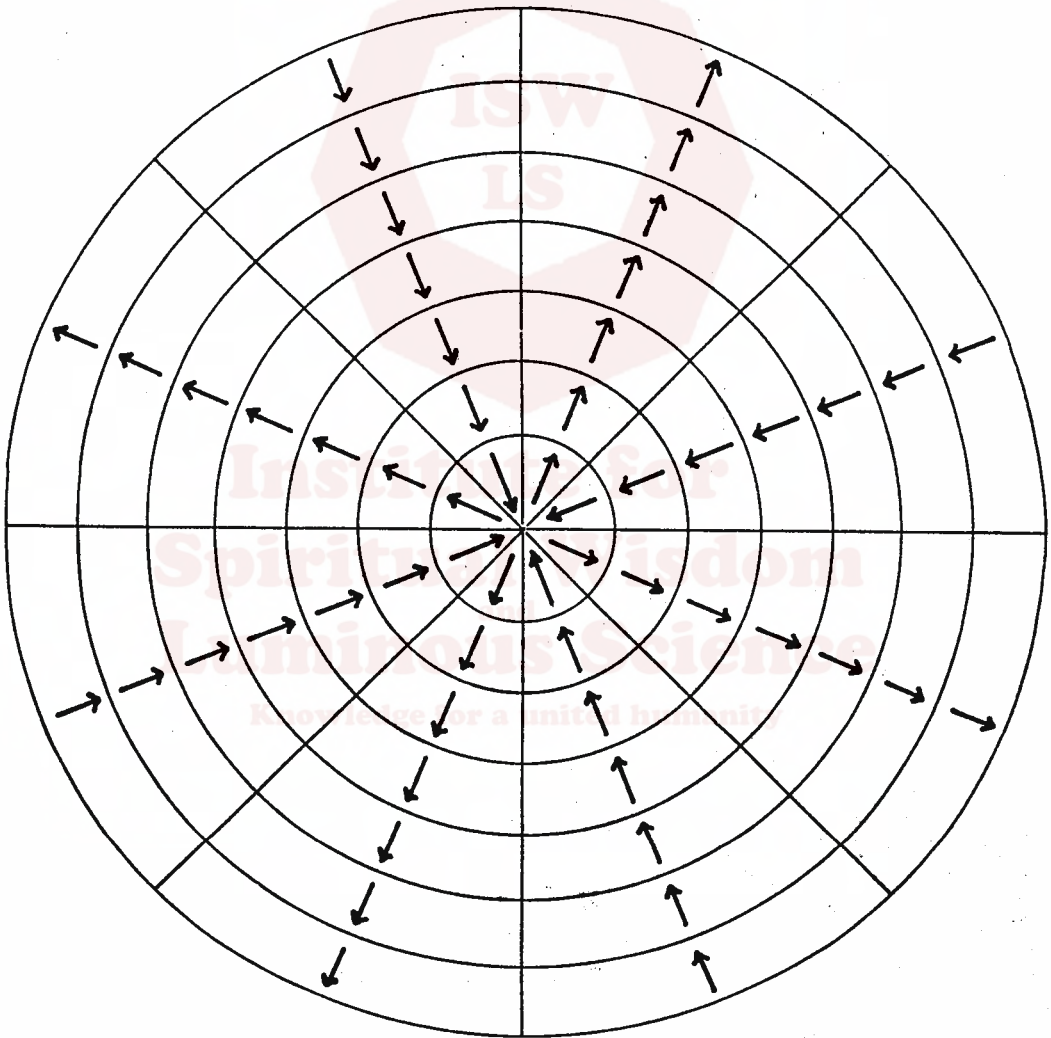

THE SHOWER OF KNOWLEDGE AND WISDOM

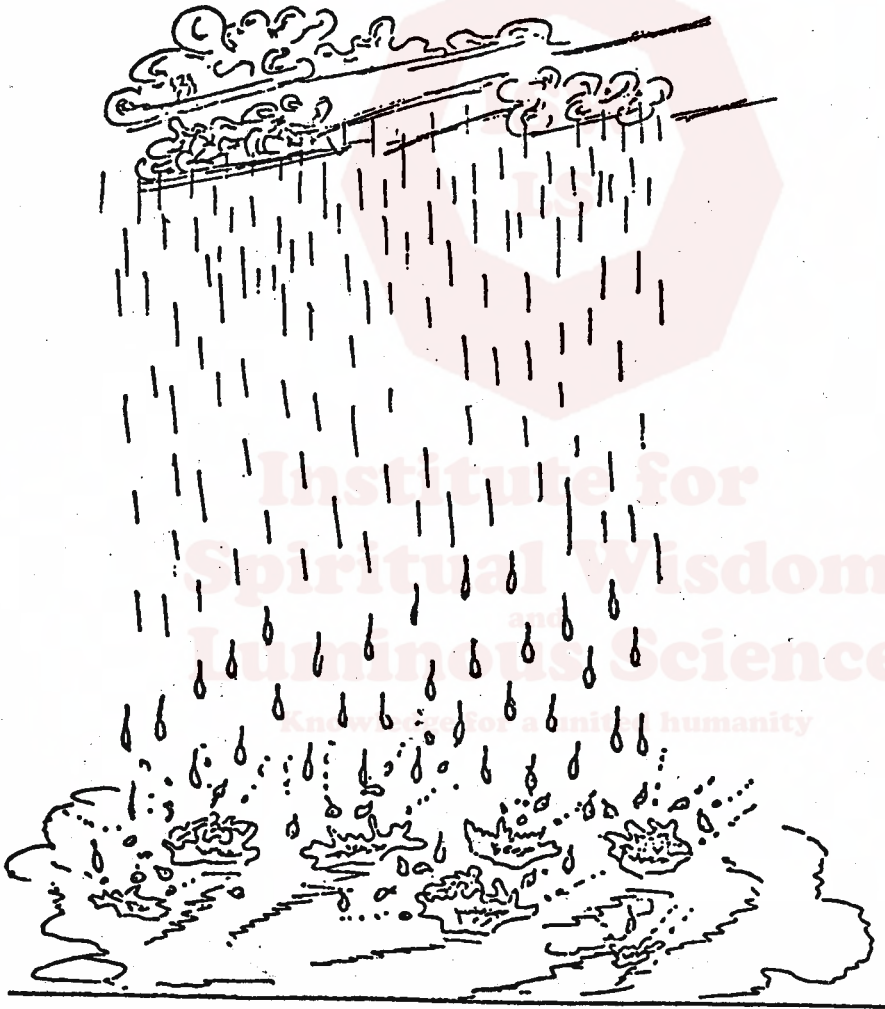

"AND WE SEND DOWN PURIFYING WATER FROM THE SKY." (25: 48)
Here 'Sky' spiritually means the Holy Prophet and his successor, the Imam,
The 'Purifying Water' means their knowledge and wisdom.

No. 33(A)

THE SHOWER OF KNOWLEDGE AND WISDOM

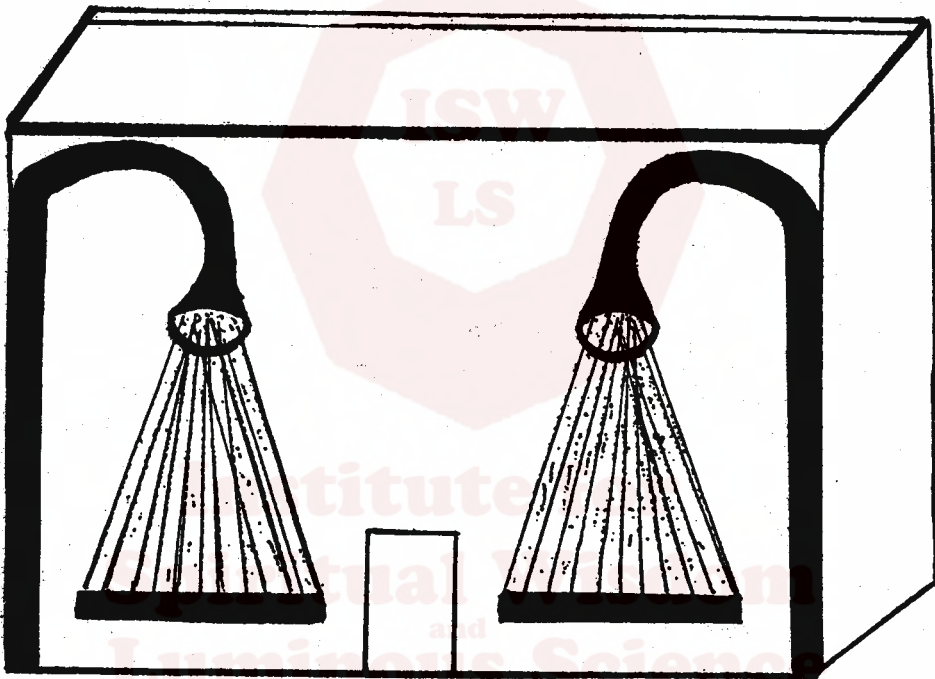

"AND WE SEND DOWN PURIFYING WATER FROM THE SKY." (25: 48)

SPIRITUAL HOSPITAL

Indeed the Holy Qur'an is a Spiritual Hospital and the Imam of the time is the Spiritual Doctor. As God says: "AND WE REVEAL OF THE QUR'AN THAT WHICH IS A HEALING AND A MERCY FOR BELIEVERS." (17:82) Also see : 9:14, 10:57, 41:44

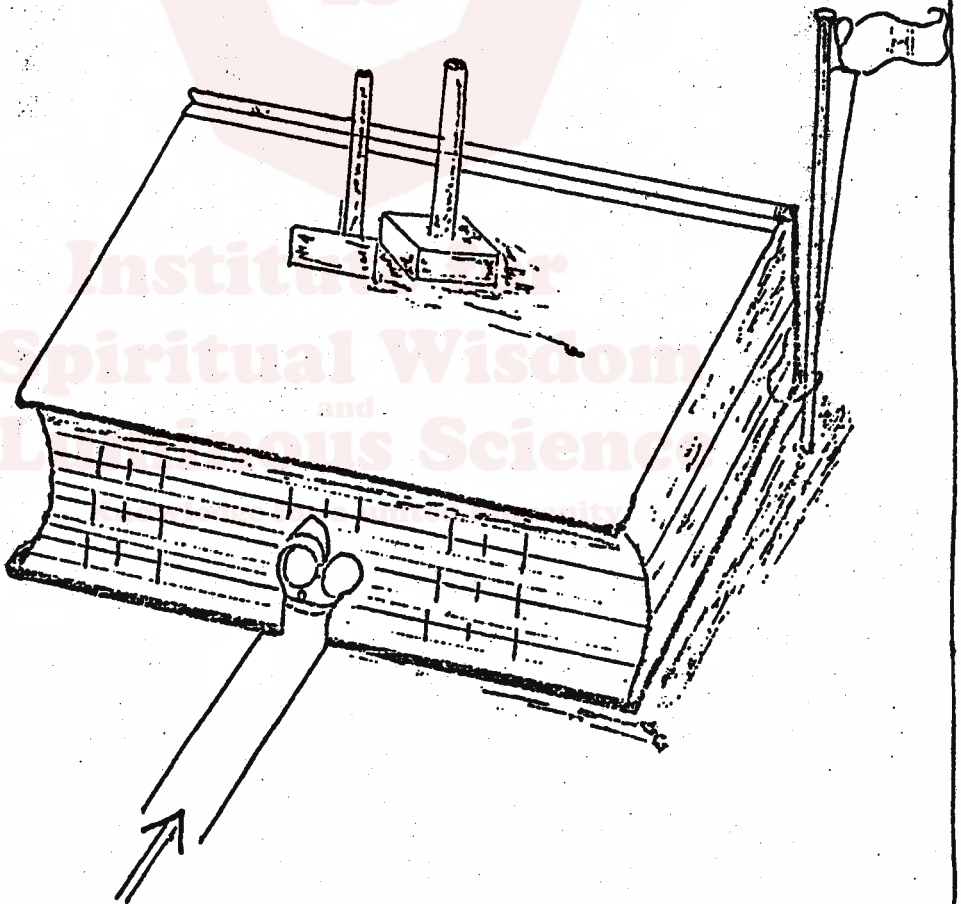

AHL-I BAIT

Allah's wish is but to remove uncleanness far from you, O folk of the household, and cleanse you with a thorough cleansing. (33 : 33)

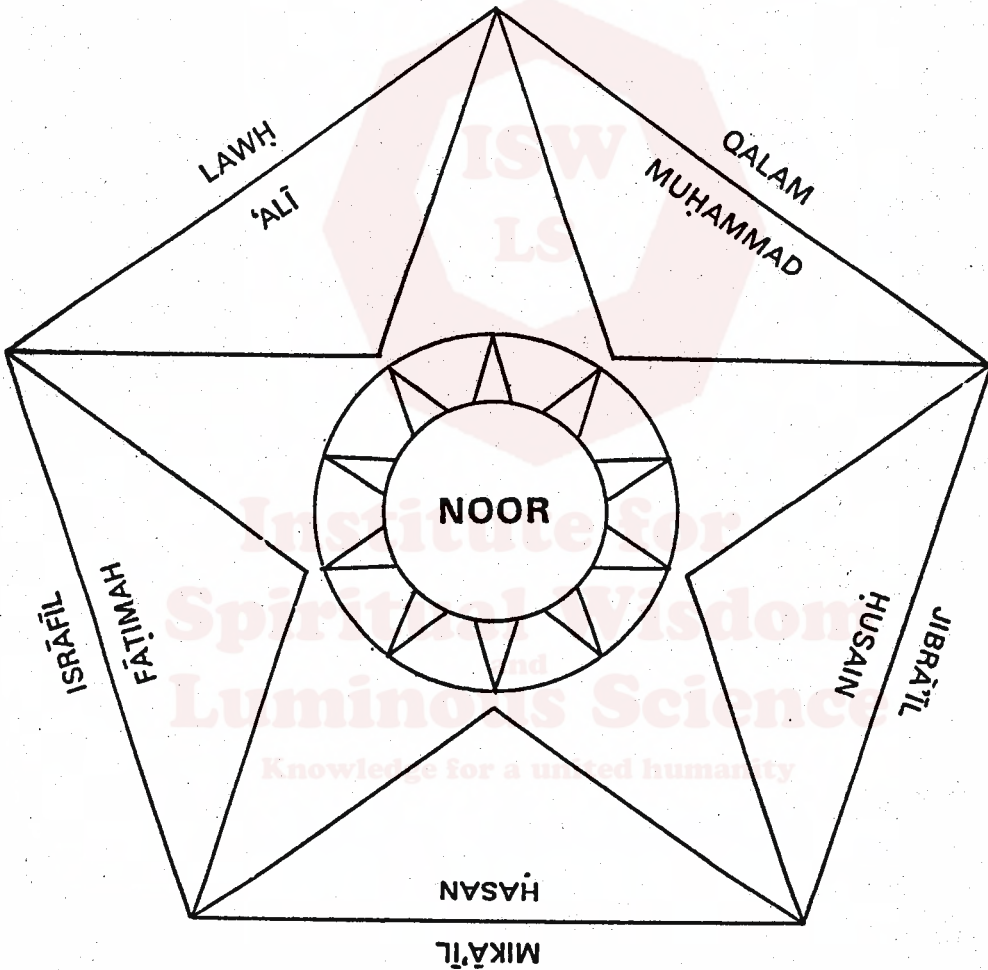

Say : Come ! We will summon our sons and your sons, and our women and your women, and ourselves and yourselves. (3 : 61)

UMM AL-KITĀB
AMALKTAB

A M A L K T A B

$$1 + 40 + 1 + 30 + 20 + 400 + 1 + 2 = 495$$

$$495 = 4 + 9 + 5 = 18 = 1 + 8 = 9. \text{ THE ANSWER IS } 9$$

ḤUDŪD-I DĪN	FORMULA
MUSTAJĪB	1
MĀZŪN-I AŞGHAR	2
MĀZŪN-I AKBAR	3
DĀ'Ī-I MAKFŪF	4
DĀ'Ī-I MUTLAQ	5
HUJJAT	6
BĀB	7
IMĀM	8
ASĀS ('ALĪ)	9
NĀṬĪQ (MUḤAMMAD)	10
NAFS-I KULL	100
'AQL-I KULL	1000

UMM AL-KITĀB MEANS "THE MOTHER OF THE BOOK"

THE FIGURE 9 INDICATES THAT MAWLĀ 'ALĪ THE MOTHER OF THE BOOK, SO THE HOLY QUR'ĀN IS HIGH AND FULL OF WISDOM IN 'ALĪ.

"WE HAVE MADE IT A QUR'ĀN IN ARABIC, THAT YE MAY BE ABLE TO UNDERSTAND. AND VERILY, IT IS IN THE MOTHER OF BOOK, IN OUR PRESENCE, HIGH, FULL OF WISDOM". (43 - 3, 4)

THE BLESSED CIRCLE OF

IMĀM AL-BĀQIR

THE WANDERING ARABS SAY : WE BELIEVE.SAY (UNTO THEM O MUḤAMMAD) : YE BELIEVE NOT, BUT RATHER SAY, "WE SUBMIT," FOR THE ĪMĀN, HATH NOT YET ENTERED INTO YOUR HEARTS. (49 : 14)

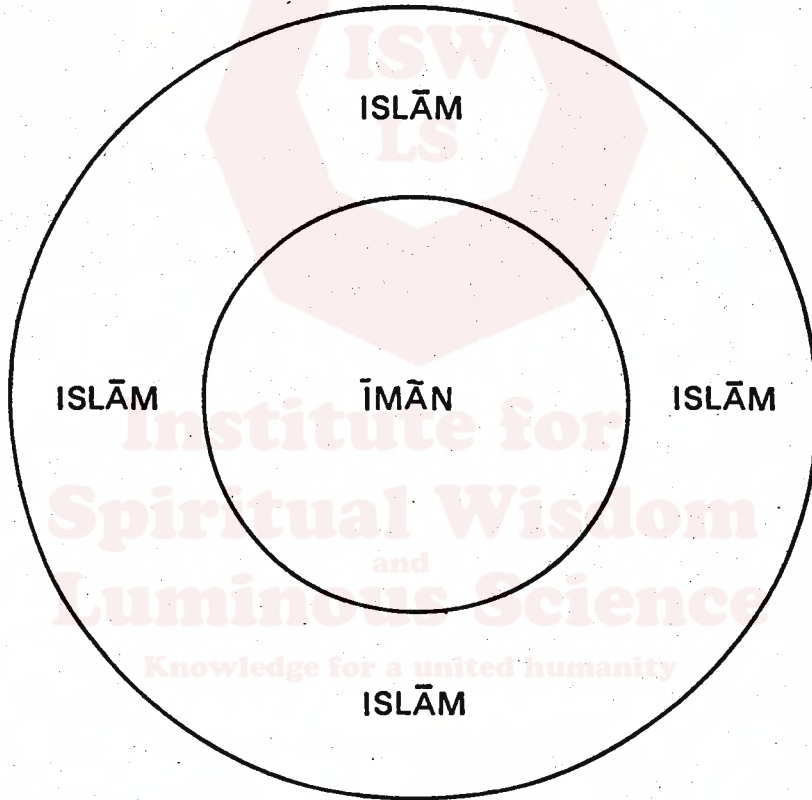

.....IMĀM AL-BĀQIR OPENED HIS HAND, AND DREW A SMALL CIRCLE ON HIS PALM, AND SAID : THIS CIRCLE REPRESENTS THE FAITH (ĪMĀN). THEN HE DREW A LARGER CIRCLE AROUND IT.....AND SAID : THIS IS THE CIRCLE OF RESIGNATION (ISLĀM)

NO: 40 A

60
THE BLESSED CIRCLE

MEANS:

Now Hath Come Unto You Light From Allāh And A Manifest Scripture. (5: 15)

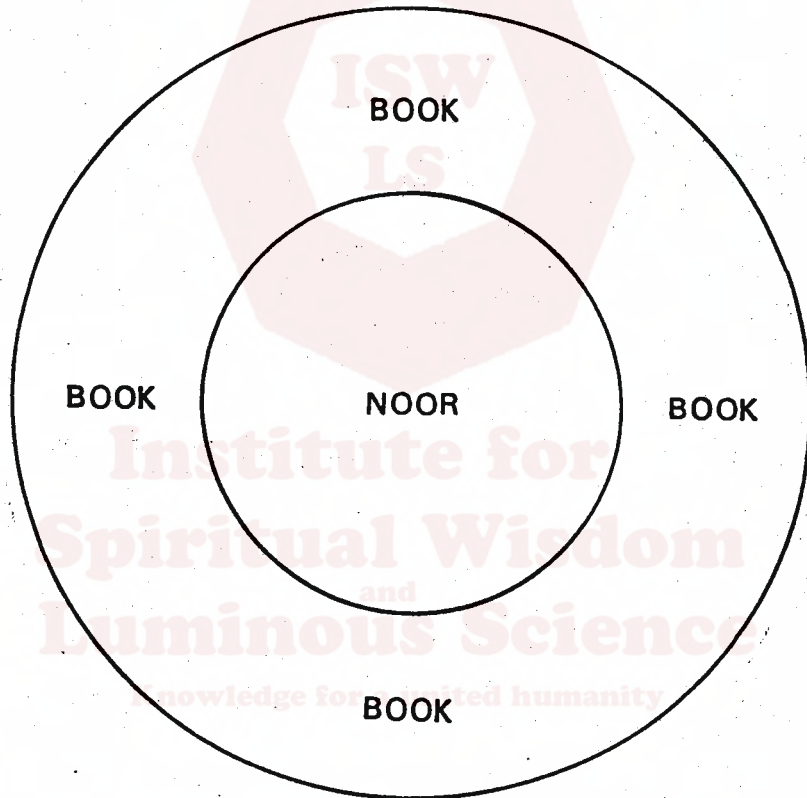

Whereby Allāh Guided Him Who Seeketh His Good Pleasure Unto Paths of Peace.
He Bringeth Them Out of Darkness Unto Light By His Decree, And Guideth Them
Unto A Straight Path. (5: 16)

No. 40(B)

THE BLESSED CIRCLE

MEANS:

AND TEACHETH YOU THE SCRIPTURE AND WISDOM.
AND TEACHETH YOU THAT WHICH YE KNEW NOT. (2: 15)

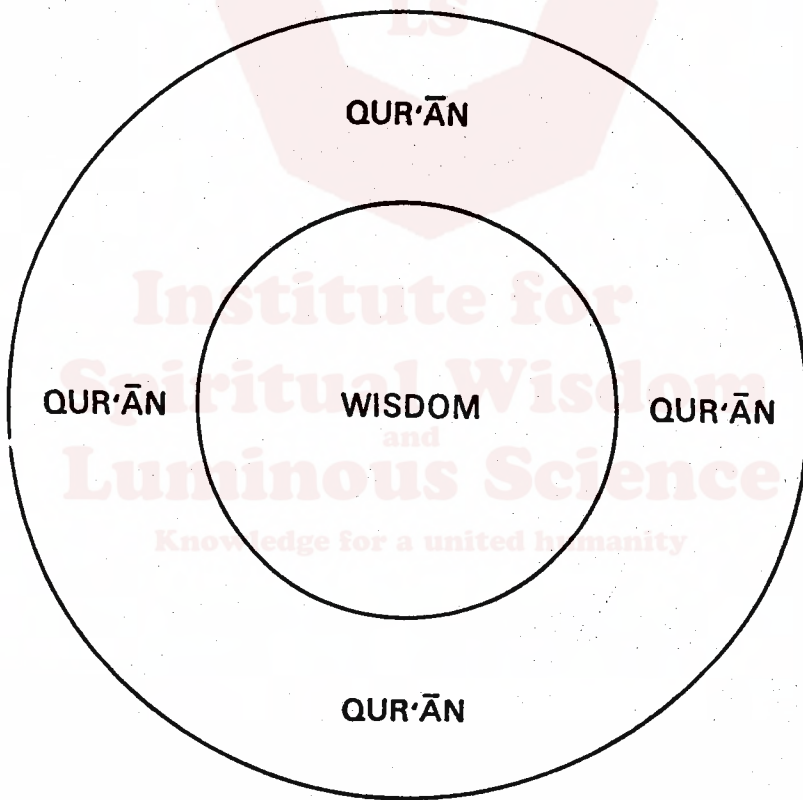

THE BLESSED CIRCLE MEANS:

SEE YE NOT HOW ALLAH HATH MADE SERVICEABLE UNTO YOU
WHAT SOEVER IS IN THE SKIES AND WHAT SOEVER IS IN THE EARTH
AND HATH LOADED YOU WITH HIS FAVOURS BOTH ZĀHIR AND
BĀTIN (31:20)

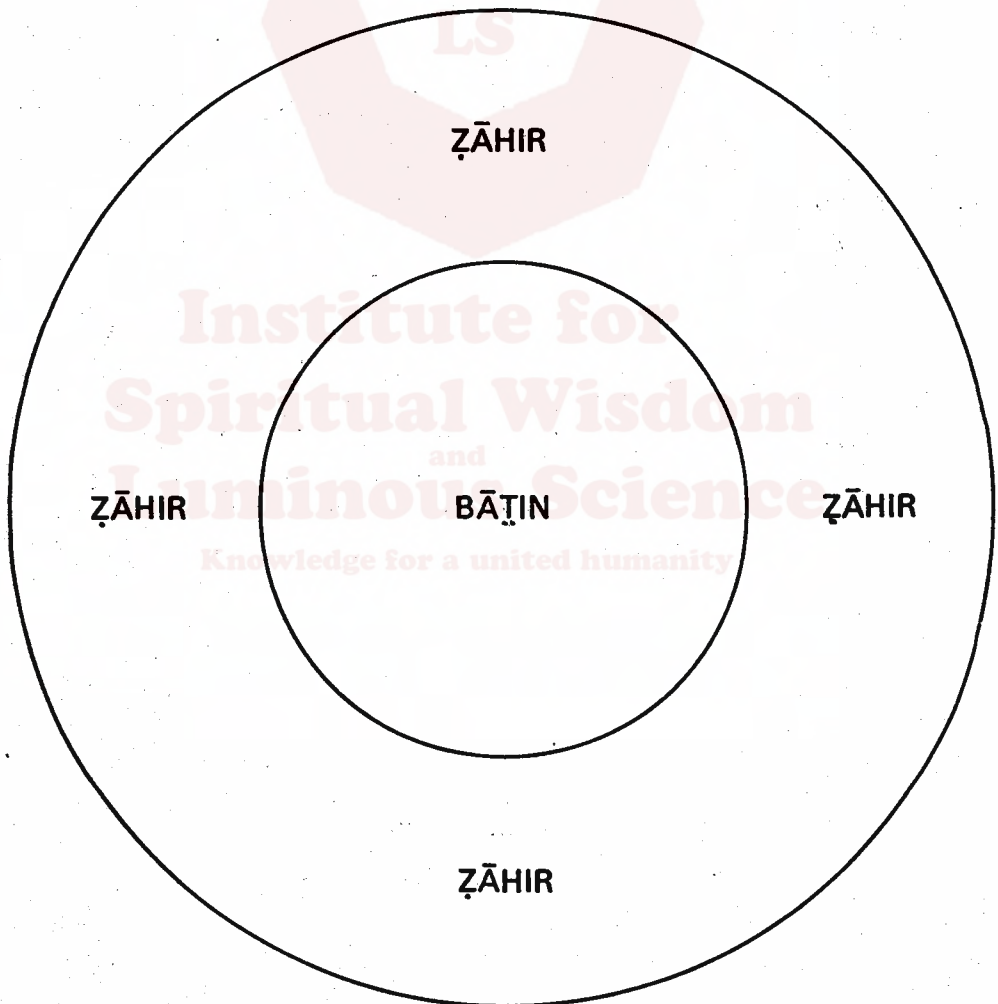

THE BLESSED CIRCLE MEANS:

THUS THY LORD WILL PREFER THEE AND WILL TEACH THEE
THE TĀWĪL OF SAYINGS AND WILL PERFECT HIS GRACE
UPON THEE. (12:6)

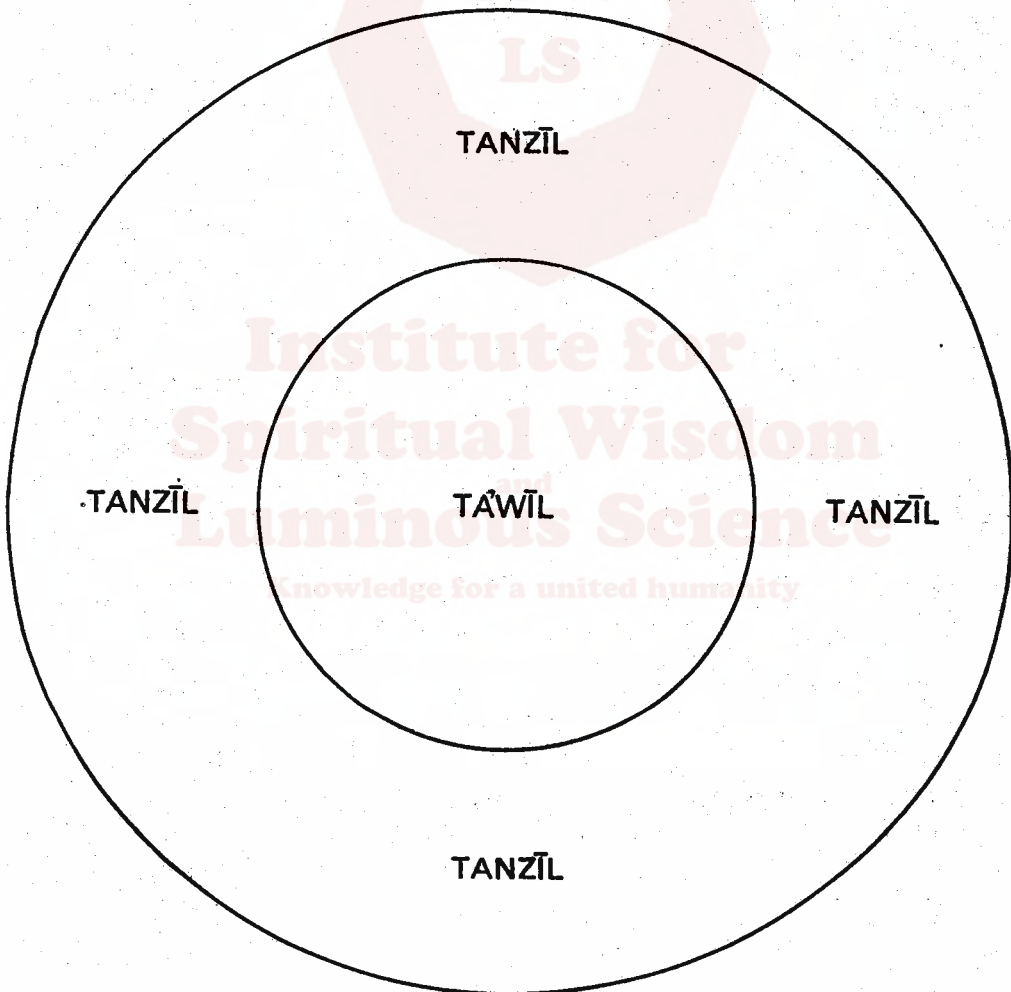

NOOR INVITES MOMINS

O MOMINS, RESPOND TO GOD AND THE PROPHET WHEN HE INVITES YOU TO SOMETHING WHICH WILL GIVE YOU LIFE (8:24)

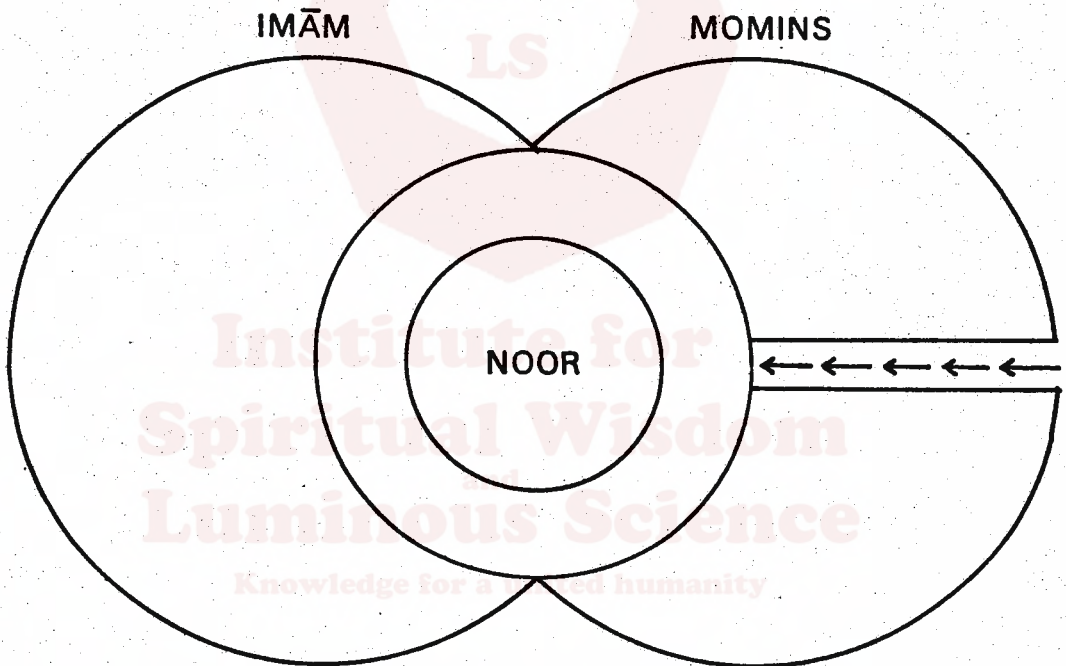

O SON OF ADAM! OBEY ME, I SHALL MAKE YOU LIKE ME. YOU WILL BE ALIVE FOREVER, AND DEATH WILL NOT COME TO YOU....

(Hadis-i Quds)

NOOR INVITES MOMINS

ALLAH GUIDETH UNTO HIS NOOR WHOM HE WILL. AND ALLAH SPEAKETH TO MANKIND IN ALLEGORIES, FOR ALLAH IS KNOWER OF ALL THINGS (24 : 35)

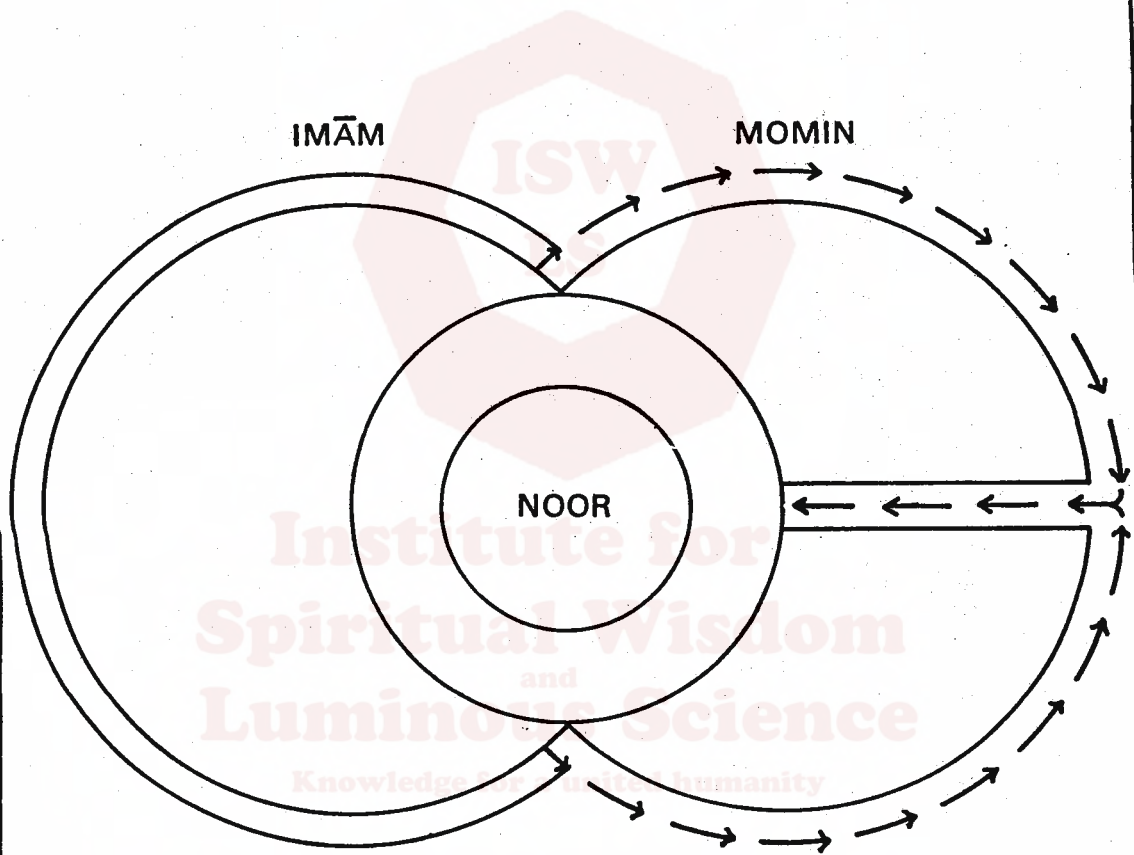

IMAM'S GUIDANCE BY MEANS OF: KNOWLEDGE → → → →
 WISDOM → → → →

NOOR INVITES MOMINS

SAY, IF YE (ACTUALLY) LOVE ALLAH, FOLLOW ME; ALLAH WILL LOVE YOU AND FORGIVE YOU YOUR SINS. ALLAH IS FORGIVING MERCIFUL (3: 31)

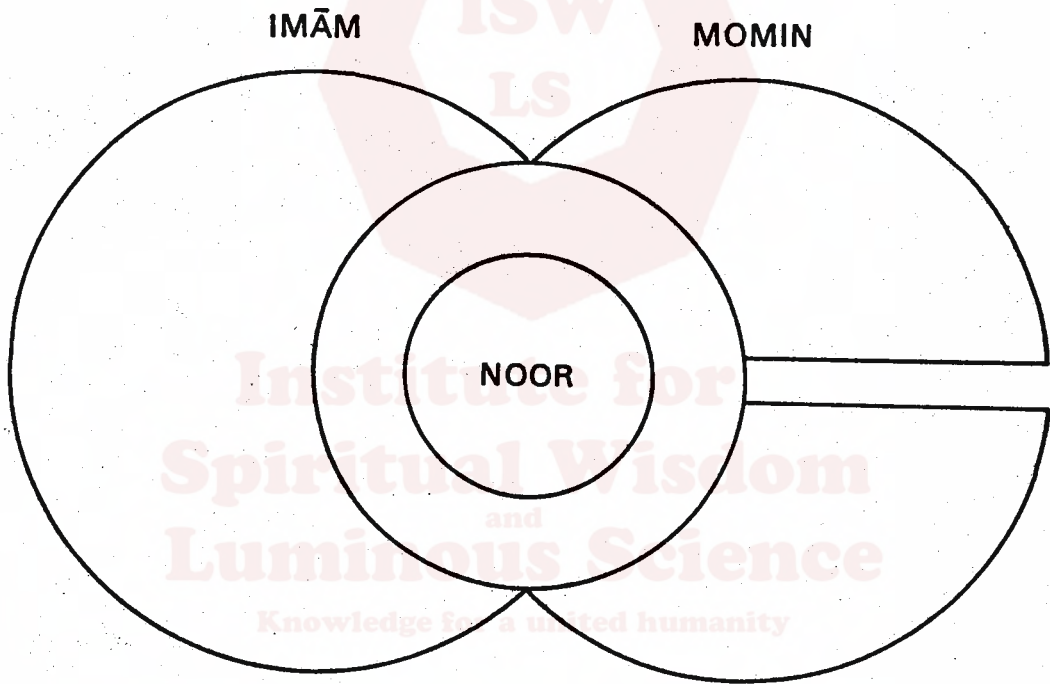

MY SERVANT CONTINUES TO DRAW NEAR TO ME THROUGH WORKS OF SUPEREROGATION, UNTIL I LOVE HIM. AND WHEN I LOVE HIM, I AM HIS EAR, SO THAT HE HEARS BY ME, AND HIS EYE, SO THAT HE SEES BY ME, AND HIS TONGUE, SO THAT HE SPEAKS BY ME, AND HIS FOOT, SO THAT HE WALKS BY ME (Ḥadīṣ Qudsī)

NOOR INVITES MOMINS

ON THE DAY WHEN THOU (MUHAMMAD) WILT SEE THE BELIEVERS,
MEN AND WOMEN, THEIR NOOR SHINNING FORTH BEFORE THEM
AND THEIR RIGHT HANDS, (AND WILT HEAR IT SAID UNTO THEM):
GLAD NEWS FOR YOU THIS DAY (57 : 12)

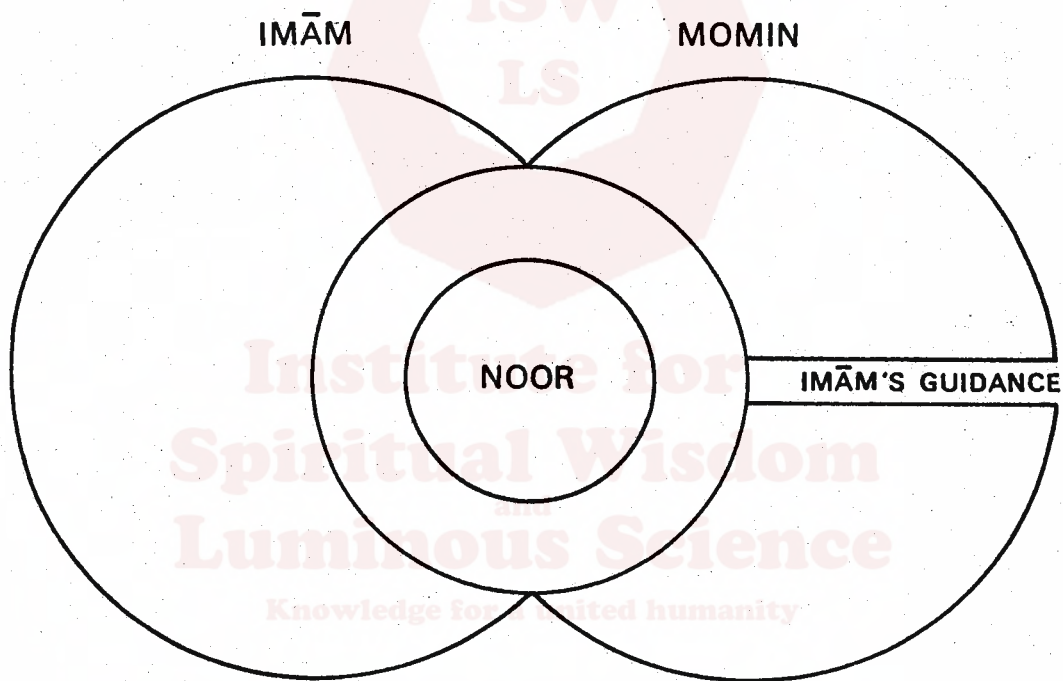

WHOSO IS BLIND HERE WILL BE BLIND IN THE HEREAFTER,
AND YET FURTHER FROM THE ROAD (17 : 72)

NOOR INVITES MOMINS

AND THOSE WHO BELIEVE IN ALLAH AND HIS MESSENGERS,
THEY ARE THE UPRIGHTS; AND THE MARTYRS ARE WITH THEIR
LORD; THEY HAVE THEIR REWARD AND THEIR NOOR (57 : 19)

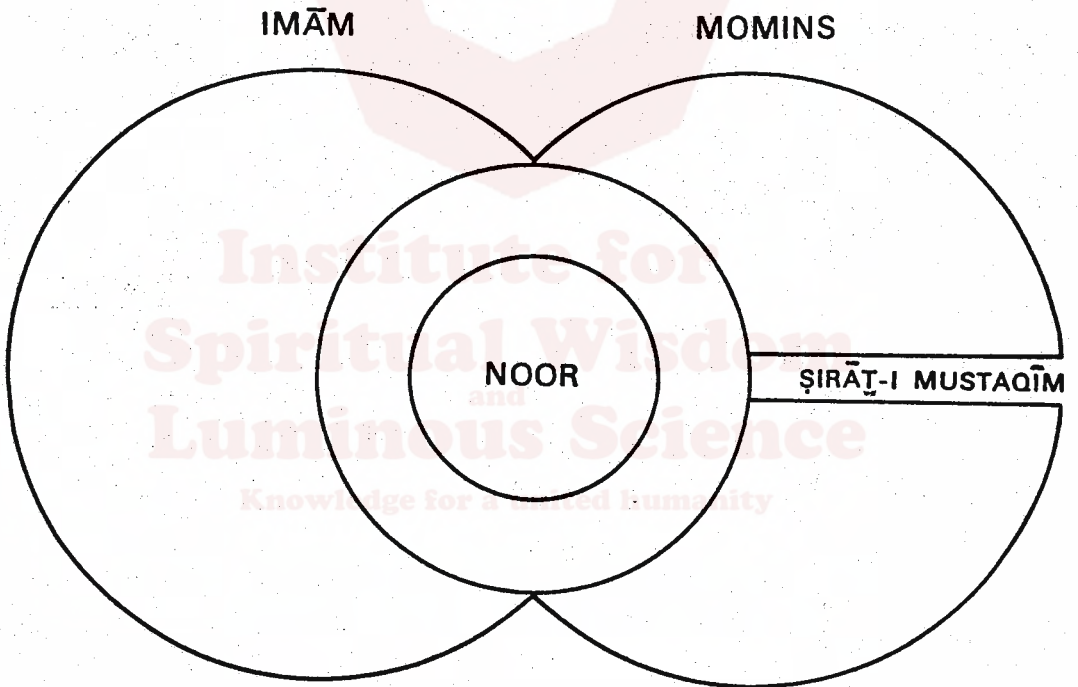

HE WHO HOLDETH FAST TO ALLAH, HE INDEED IS GUIDED
UNTO A RIGHT PATH (3 : 101)

THE ARK OF NOAH

SO WE INSPIRED HIM : CONSTRUCT THE ARK WITH OUR SIGHT AND UNDER OUR GUIDANCE (23:27)

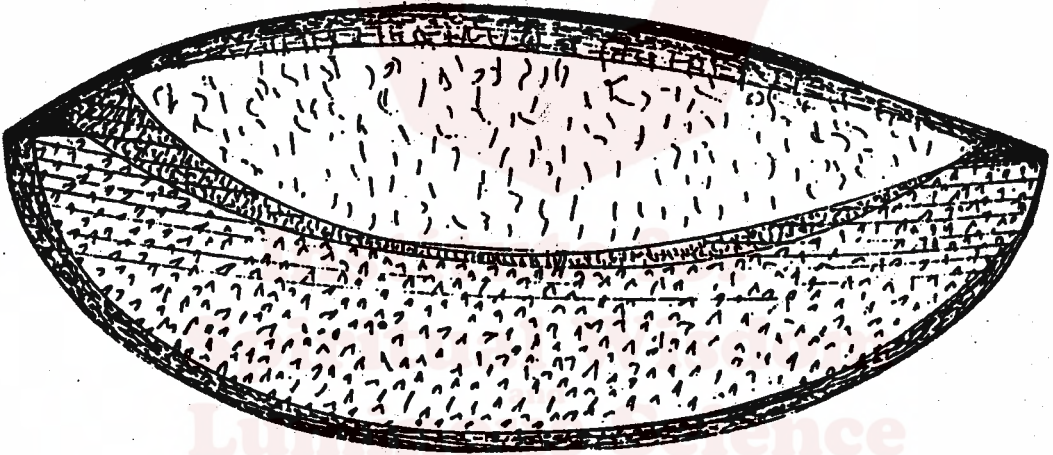

سنة اهل بيتي فيكم كسفينة نوح، من راكبها نجا ومن تخلف عنها غرق -

THE PEOPLE OF MY HOUSEHOLD ARE LIKE UNTO THE ARK OF NOAH, HE WHO BOARDED IT WAS SAVED AND HE WHO TURNED AWAY WAS LOST.

THE USŪL AND FURŪ' OF RELIGION

SEEST THOU NOT HOW ALLAH COINETH A SIMILITUDE: A GOODLY SAYING, AS A GOODLY TREE, ITS ROOT SET FIRM, ITS BRANCHES REACHING INTO HEAVEN (14: 24)

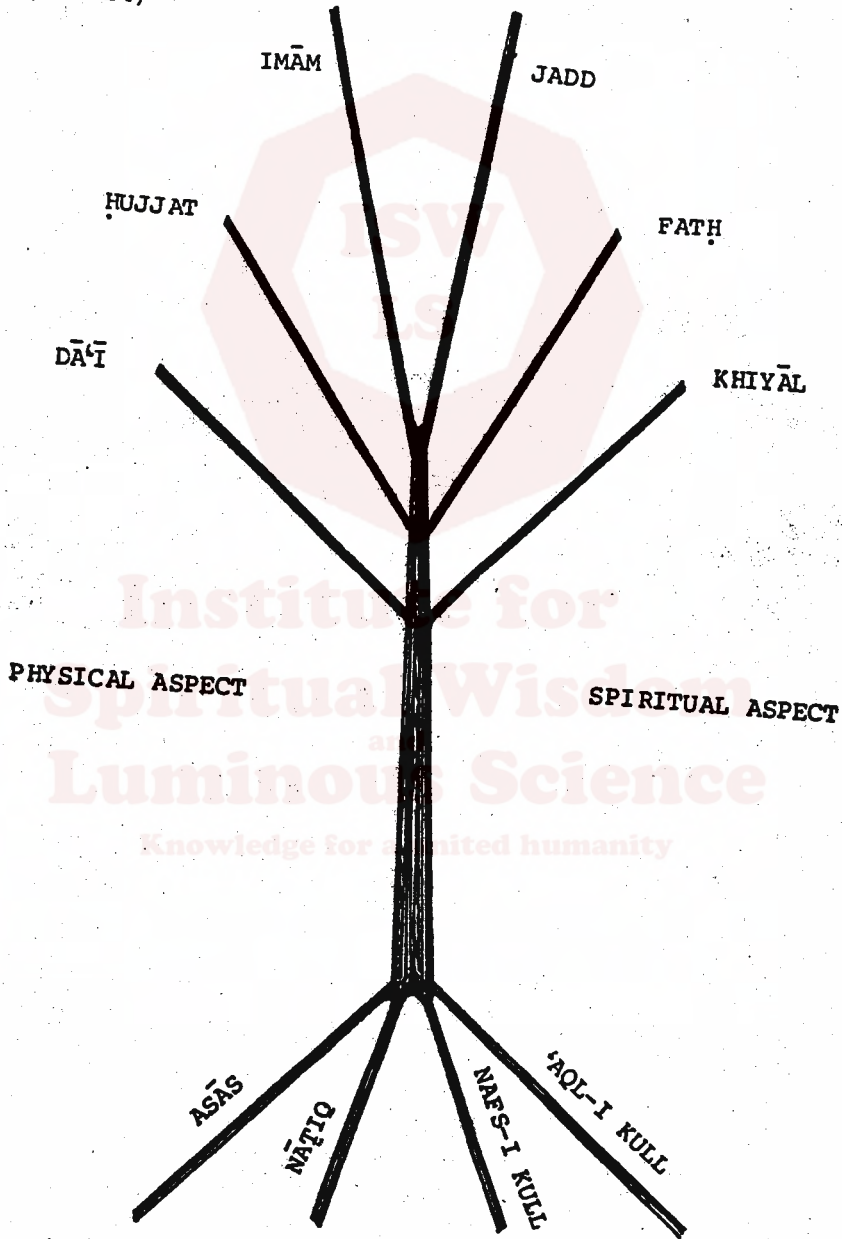

UNITY OF THE REAL TORAH AND MOSES

SAY: WHO RELEASED THE BOOK WHICH MOSES BROUGHT, A LIGHT (NŪR) AND GUIDANCE FOR MANKIND, WHICH YE HAVE PUT ON PARCHMENTS, WHICH YE SHOW, BUT YE HIDE MUCH.(6:91)

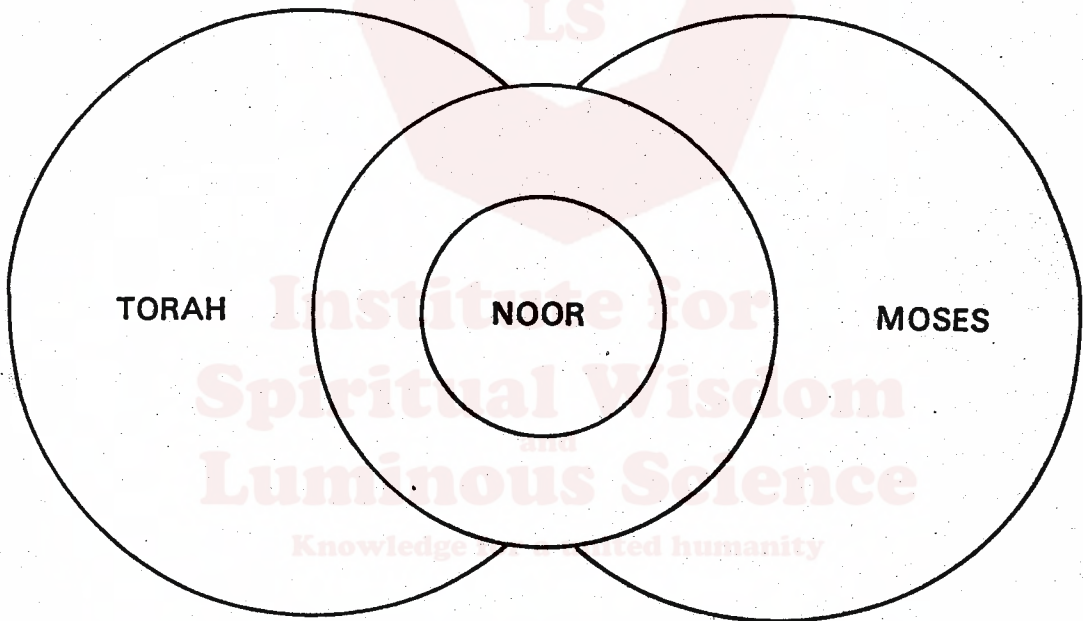

NOTE: THE ABOVE HOLY ĀYAT SHOWS CLEARLY THAT THE REAL AND SPIRITUAL TORAH WAS RŪḤ AND NŪR (LIGHT) IN MOSES.

UNITY OF MOSES AND AARON

LO I WE DID REVEAL THE TORAH. WHEREIN IS GUIDANCE AND A LIGHT, BY WHICH THE PROPHETS WHO SURRENDERED (UNTO ALLAH) JUDGED THE JEWS AND THE RABBIS AND THE PRIESTS. (5:44)

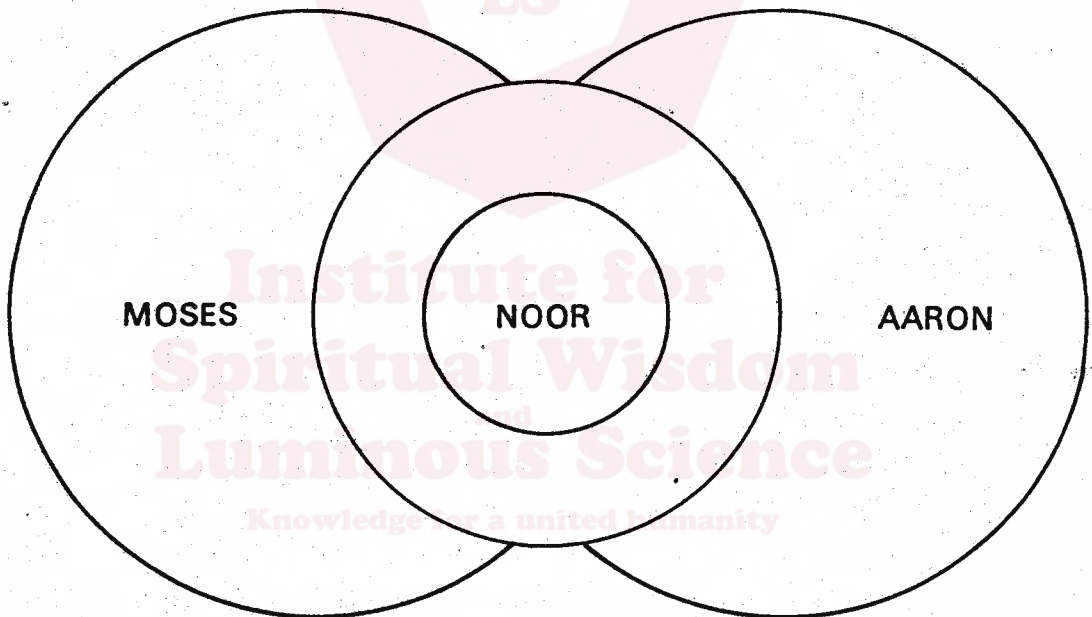

NOTE: THE LIVING LIGHT OF THE TORAH WAS IN MOSES AND AARON, WHEREIN THEY WERE ONE WITH THE BOOK OF ALLAH, BECAUSE THE LIGHT IS A LIVING SOUL (42:52) WHICH CAN ONLY LIVE IN A PERFECT MAN.

UNITY OF THE TORAH AND AARON IN NOOR

AND WE VERILY GAVE MOSES AND AARON THE CRITERION (OF RIGHT AND WRONG) AND A LIGHT AND A REMINDER FOR THOSE WHO KEEP FROM EVIL (21 : 48)

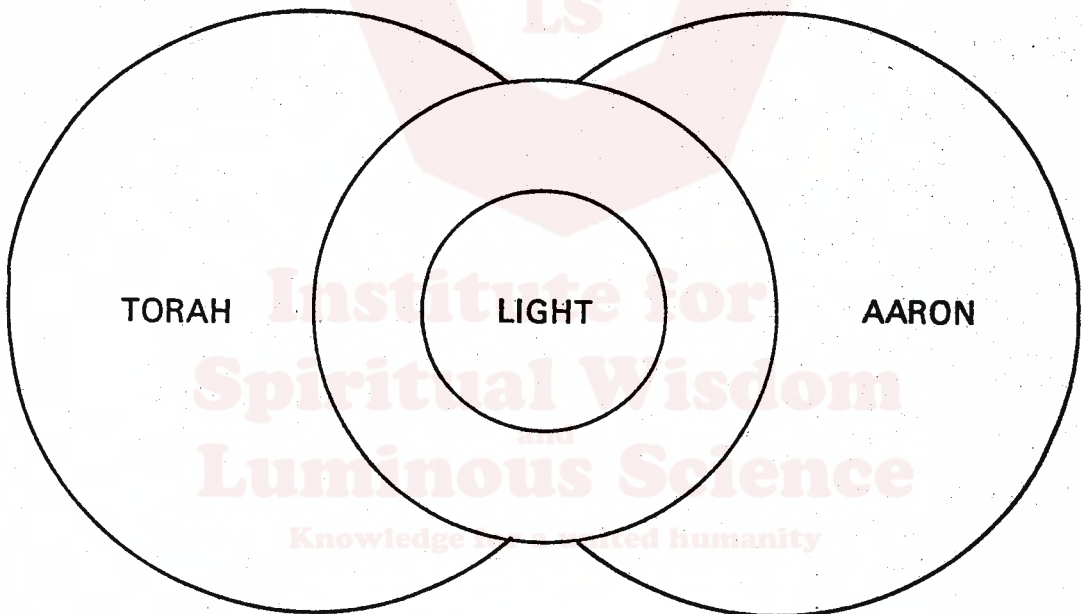

THE DIVINE LIGHT, WHICH WAS GIVEN TO BOTH : MOSES AND AARON, WAS NOOR-I HIDAYAT (THE LIGHT OF GUIDANCE) OF TORAH, WHICH WAS IN THE FORM OF AN EXALTED SOUL IN PROPHET MOSES AND IMAM AARON, SO THEY WERE ONE AND THE SAME SPIRITUALLY WITH THE REVEALED BOOK IN THIS NOOR.

AARON WAS THE SPEAKING BOOK

AND BEFORE IT WAS THE BOOK OF MOSES, AN IMAM AND A
MERCY (11 : 17)

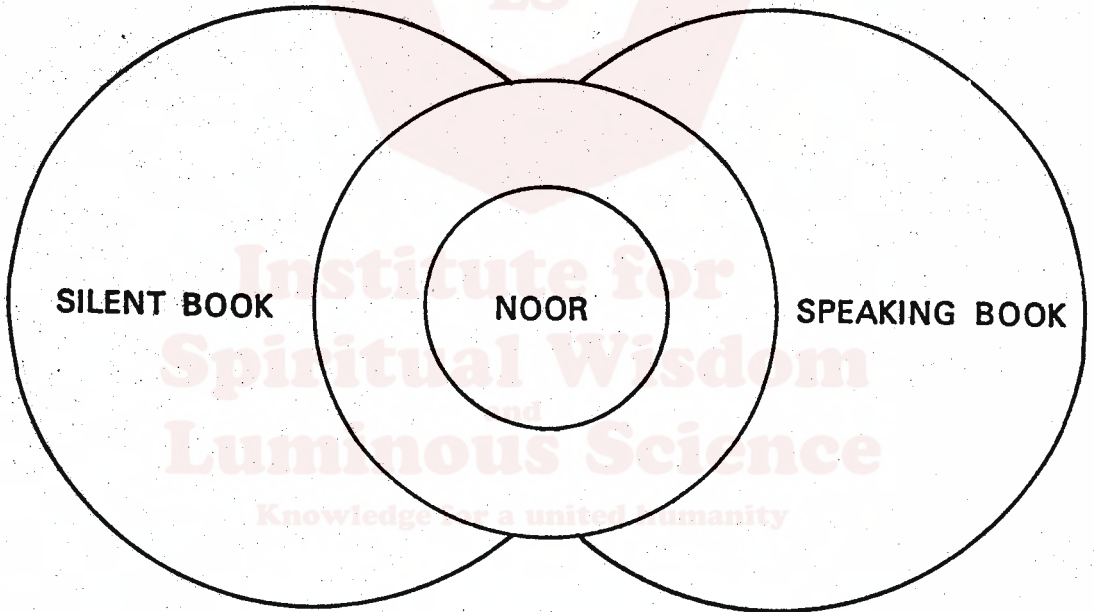

NOTE : IT MEANS THAT THE DIVINE BOOK IN ITS ORIGINAL AND SPIRITUAL POSITION IS THE IMAM, BEING A LIVING SOUL (LIGHT) IN HIM, AND THUS THE IMAM IS CALLED THE SPEAKING BOOK OF GOD, AS IT IS EVIDENT FROM THE ABOVE AYAT THAT IMAM AARON WAS THE SPEAKING BOOK OF ALLAH IN HIS TIME.

THE WAZIR OF MOSES

WE VERILY GAVE MOSES THE SCRIPTURE AND PLACED WITH HIM HIS BROTHER AARON AS HIS WAZIR.

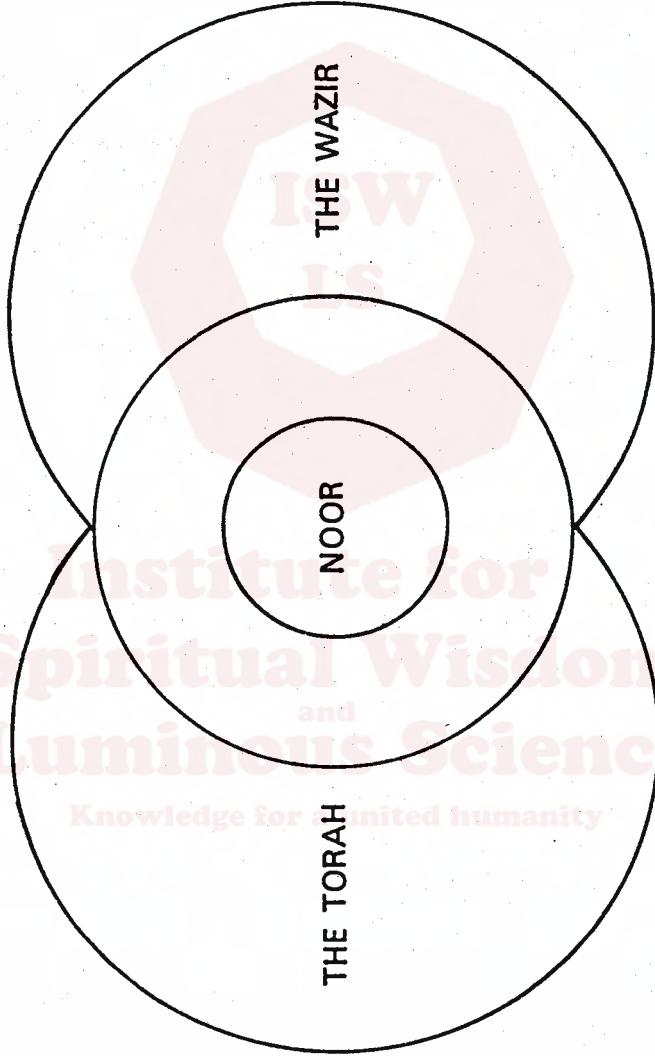

NOTE: THE ARABIC WORD 'WAZIR' IS FROM THE ROOTS OF 'WIZR' (LOAD, BURDEN). THUS WAZIR LITERALLY MEANS: SOMEONE WHO CARRIES A HEAVY BURDEN, AND THE HOLY ĀYAT INDICATES THAT THE HEAVY LOAD WAS THE TORAH, WITH ALL ITS TEACHINGS AND DUTIES, AND THE WAZIR OR THE CARRIER OF THIS HEAVY BURDEN WAS THE IMAM AARON, AS A SECULAR WAZIR IS ALWAYS RESPONSIBLE AND ANSWERABLE FOR A KING.

NO : 44 (E)

THE BOX OF PEACE

LO! THE TOKEN OF HIS KINGDOM IS THAT THERE SHALL COME UNTO YOU THE BOX WHEREIN IS PEACE OF REASSURANCE FROM YOUR LORD, AND A REMNANT OF THAT WHICH THE HOUSE OF MOSES AND THE HOUSE OF AARON LEFT BEHIND, THE ANGELS BEARING IT. LO! HEREIN SHALL BE A TOKEN FOR YOU IF (IN TRUTH) YE ARE BELIEVERS. (2: 248)

THE BOX OF PEACE

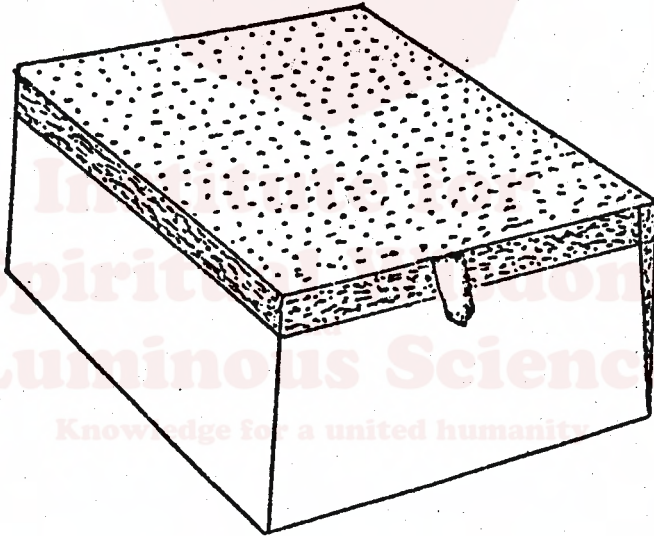

NOTE: THE BOX OF PEACE MEANS PRACTICAL SPIRITUALISM, WHICH IS THE TOKEN OF IMAM'S SPIRITUAL KINGDOM, WHEREIN IS THE PEACE OF AIN AL-YAQIN (THE VISION OF CERTAINTY).

SOME MYSTICAL TITLES OF 'ALĪ

No.	Title	No.	Title
1	Al-Bait (2: 125)	13	Lailat al-Qadr (97: 1)
2	Nūr (7: 157)	14	Dābat al-Ard (27: 82)
3	'Alim (29: 43)	15	Sa'ah (25:11)
4	'Alim (35: 28)	16	Rajifah (79: 6)
5	Mutawassim (15: 75)	17	Mīzān (42: 17)
6	Urwat al-Wusqa (31: 22)	18	al-Shajarah (28: 30)
7	Kawṣar (108: 1)	19	Hajar al-Makram (2: 60)
8	Imām-i Muttaqīn (25: 74)	20	Wajh u-Allāh (55: 27)
9	Imām-i Mubīn (36: 12)	21	Janb u-Allāh (39: 56)
10	Zālik al-Kitāb (2: 2)	22	Uzun Wa'iyah (69: 12)
11	Bait al-Atiq (22: 29)	23	Walī (10: 62)
12	Yawm Ākhir (4: 136)	24	A'zam (9: 20)

SOME MYSTICAL TITLES OF ALI (TRANSLATION)

NO	TITLE	NO	TITLE
	THE HOUSE OF GOD	13	THE NIGHT OF POWER (QADR)
2	THE LIGHT	14	DĀBAH OF THE EARTH
3	THE WISE	15	THE HOUR
4	THE ERUDITE	16	THE CAUSER OF TREMBLING
5	READER OF SIGNS	17	THE BALANCE
6	THE FIRM HAND-HOLD	18	THE TREE (OF TŪR)
7	THE MAN WHO HAS MORE OFFSPRING	19	THE BLESSED ROCK (OF MOSES)
8	IMAM OF THOSE WHO FEAR GOD	20	THE FACE OF ALLAH
9	MANIFESTING IMAM (36:12)	21	NEARNESS OF GOD
10	THE BOOK	22	REMEMBERING EARS
11	THE ANCIENT HOUSE (OF GOD)	23	THE FRIEND (OF GOD)
12	THE LAST DAY	24	GREAT

THE HIDDEN BOOK

NAY, I SWEAR BY THE PLACES OF THE STARS-AND LO'
 THAT VERILY IS A TREMENDOUS OATH, IF YE BUT KNEW-THAT
 (THIS) IS INDEED A NOBLE QUR'AN, IN A BOOK KEPT HIDDEN,
 WHICH NONE TOUCHETH SAVE THE PURIFIED: (56:75-79)

THE HIDDEN BOOK

(IMĀM-I ZAMĀN)

THE HOLY QUR'ĀN

کتاب مکنون

قرآن کریم کتاب مکنون ہے

LAWḤ-I MAḤFŪZ

(IMĀM-I MUBĪN)

NAY, BUT IT IS A GLORIOUS QUR'ĀN ON A
GUARDED TABLET. (85:21-22)

LAWḤ-I MAḤFŪZ (IMĀM-I MUBĪN)

UNIVERSAL SOUL

KURSĪ

THE GLORIOUS QUR'ĀN

NAFS-I KULL

NŪR-I IMĀMAT

MYSTICAL LETTERS

THE BASIC MYSTICAL (NŪRĀNĪ) LETTERS USED IN THE HOLY QUR'ĀN ARE ONLY 14, AND THEIR TOTAL VALUE IS 693, THE JUMAL-I ASGHAR OF WHICH IS 9, AND ACCORDING TO THE FORMULA SHOWN IN DIAGRAM NO: 19 (E) AND NO: 37 THE FIGURE 9 STANDS FOR MAWLĀ 'ALĪ. SO WE BELIEVE THAT THERE ARE CERTAIN SECRETS PERTAINING 'ALĪ BEHIND ALL MYSTICAL LETTERS, WHICH ARE IN THE BEGINNING OF MANY SŪRAHS OF THE HOLY QUR'ĀN.

NŪRĀNĪ LETTERS

ا	ح	ر	س	س	ط	ع	ق	ك	ل	م	ن	ه	ي
A	H	R	S	S	T	Ā	Q	K	L	M	N	H	Y
1	8	200	60	90	9	70	100	20	30	40	50	5	10

1 8 200 60 90 9 70 100 20 30 40 50 5 10

$$\begin{array}{r}
 693 \\
 \hline
 6 \\
 9 \\
 3 \\
 \hline
 18 \\
 \hline
 1 \\
 8 \\
 \hline
 \end{array}$$

9 - THE ANSWER IS 9
FOR ASĀS ('ĀLĪ) IS 9

آیات نور / کائنات نور

MOON

33:46

24:35

SUN

VERSES PERTAINING TO NŪR

STARS



2:257, 5:15, 5:16, 5:44, 5:46, 6:1, 7:157, 9:32,



13:16, 14:1, 14:5, 24:35, 24:40, 33:43, 35:20,



39:22, 39:69, 57:9, 61:8, 64:8, 65:11, 4:174, 6:91,



6:122, 10:5, 42:52, 57:13, 57:28, 71:16, 66:8, 2:17



57:12, 57:19, 3:184, 22:8, 31:20, 35:25, 25:61,



33:46, 27:8, 28:29, 20:10, 27:7,

NOTE: THE HOLY QUR'ĀN WITH ITS ZĀHIR AND BĀTIN IS THE WORLD OF KNOWLEDGE AND WISDOM, SO ITS VERSES PERTAINING TO NŪR ARE LIKE SUN, MOON AND SHINING STARS.

NOOR

ALLAH IS THE LIGHT OF THE HEAVENS AND THE EARTH (24:35)

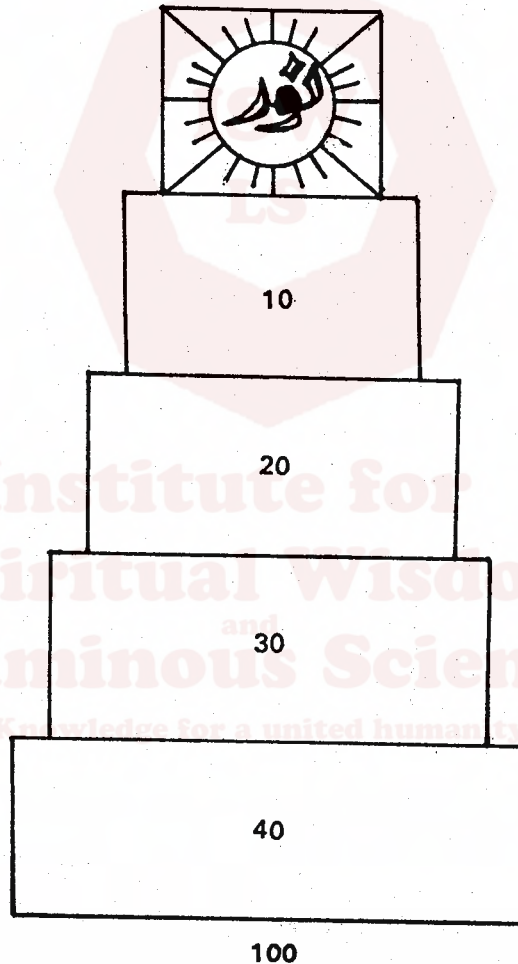

NOTE: NOOR IS ON THE PEAK OF THE LIGHTHOUSE OF ALLAH'S HUNDRED NAMES, WHICH ARE EXPLANATORY SUBJECTS OF THE HOLY QUR'AN. IN THIS SENSE THE LUMINOUS NAME OF GOD (AL-NOOR) ALWAYS SHEDS LIGHT ON THE ENTIRE WORLD OF RELIGION. EVEN THE 100 NAMES ARE ILLUMINATED BY THIS GREAT ISM OF ALLAH.

REVEALED BOOK

EVERY WISE MOMIN CAN SEE IN THE HOLY QUR'AN THAT THE MAIN AND CENTRAL SUBJECT OF ALL THE REVEALED BOOKS WAS 'THE GUIDANCE AND NOOR', AS ALLAH SAID:

LO ! WE DID REVEAL THE TORAH, WHEREIN IS THE GUIDANCE AND A NOOR (5:44)
 AND WE BESTOWED ON HIM (JESUS) THE GOSPEL WHERE- IN IS GUIDANCE AND A NOOR (5:46)
 ALLAH GUIDETH UNTO HIS NOOR WHOM HE WILL (24:35)

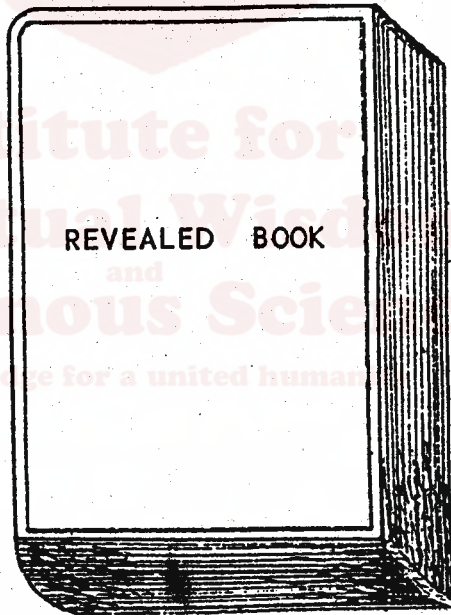

NOTE: THE LAST ĀYAT INDICATES THAT THE GUIDANCE MEANS RECOGNITION OF THE NOOR (IMAM) ESPECIALLY WHEN THE WORD 'GUIDANCE' COMES BEFORE NOOR, AS IN THE ABOVE FIRST AND SECOND ĀYAT.

THE RECORD OF RIGHTEOUS IS IN THE IMĀM

NAY, BUT THE RECORD OF THE RIGHTEOUS IS IN 'LLIYIN- AH,
 WHAT WILL CONVEY UNTO THEE WHAT 'LLIYIN IS!- A WRITTEN
 RECORD, TO WHICH WILL PRESENT THOSE WHO ARE BROUGHT NEAR
 (UNTO THEIR LORD. 83:18-21)

ON THE DAY WHEN WE SHALL SUMMON ALL MEN
 WITH THEIR IMAM, WHOSO IS GIVEN HIS BOOK IN
 HIS RIGHT HAND- SUCH WILL READ THEIR BOOK
 AND THEY WILL NOT BE WRONGED A SHRED (17:71)

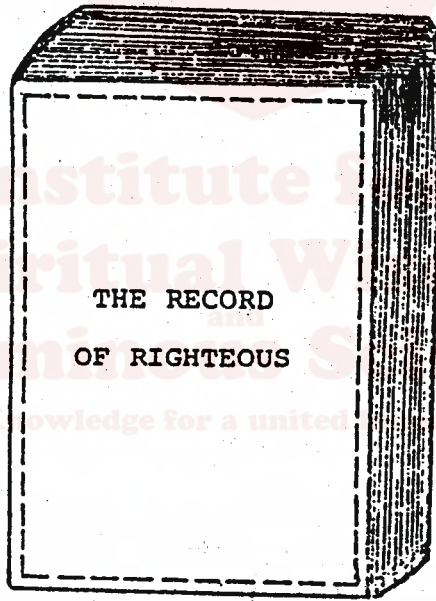

WHOSO IS BLIND HERE WILL BE BLIND IN THE
 HEREAFTER, AND YET FURTHER FROM THE ROAD
 (17:72)

TWO SUBSTANTIAL THINGS

I LEAVE BEHIND ME TWO SUBSTANTIAL THINGS AMONG YOU- THE BOOK OF GOD AND MY FAMILY, THE PEOPLE OF MY HOUSE. VERILY THEY SHALL NEVER BE SEPARATED TILL THE TWAIN RETURN TO THE POND (KAWTHAR) IN THIS MANNER-

IMĀM-I ZAMĀN

THE HOLY QUR'ĀN

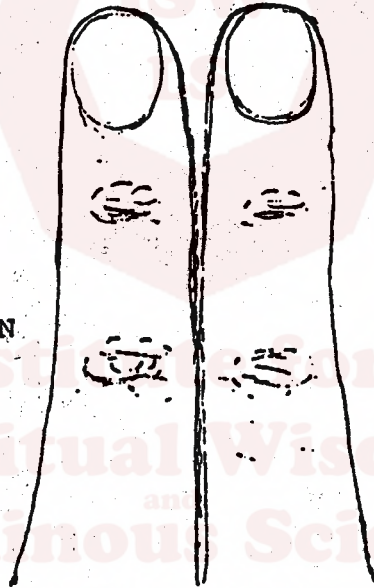

AND THE PROPHET PUT TOGETHER THE TWO INDEX FINGERS OF HIS TWO HANDS THUS, EQUALIZING THEM IN ALL RESPECTS- AND NOT LIKE THIS-AND HE SHOWED THE MIDDLE FINGER OF THE RIGHT-HAND, AND THE FIRST FINGER OF THE SAME HAND BECAUSE, SAID THE PROPHET, "THE ONE IS LONGER THAN THE OTHER. NOW BEWARE! THEIR LIKE IS THE LIKE OF NOAH'S ARK. HE WHO BOARDED IT WAS SAVED: AND HE WHO FORSOOK IT WAS DROWNED".

FOUR RIVERS OF THE PARADISE

A SIMILITUDE OF THE GARDEN WHICH THOSE WHO KEEP THEIR DUTY (TO ALLAH) ARE PROMISED; THEREIN THE RIVERS OF WATER UNPOLLUTED, AND RIVERS OF MILK WHEREOF THE FLAVOUR CHANGETH NOT, AND RIVERS OF WINE DELICIOUS TO THE DRINKERS, AND RIVERS OF CLEAR-RUN HONEY, (47 : 15)

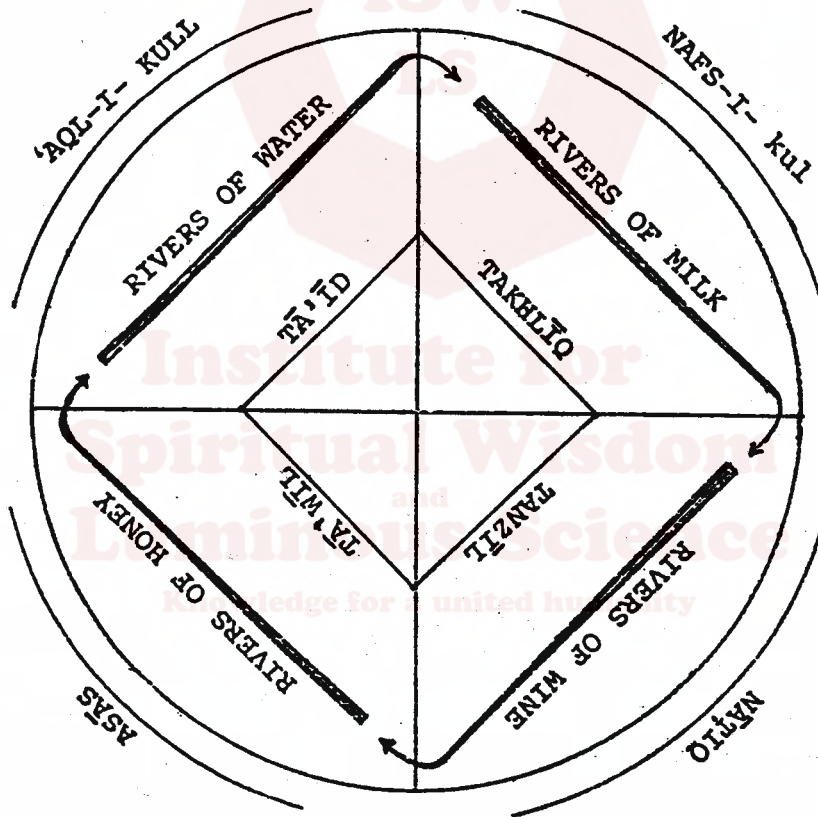

ĀDAM AND OTHERS

CAME DOWN FROM THE 8th STAGE OF PARADISE. AS GOD SAYS: WE SAID GO DOWN, ALL OF YOU, FROM HENCE: BUT VERILY THERE COMETH UNTO YOU FROM ME A GUIDANCE: AND WHOSO FOLLOWED MY GUIDANCE THERE SHALL NO FEAR COME UPON THEM NEITHER SHALL THEY GRIEVE (2:38)

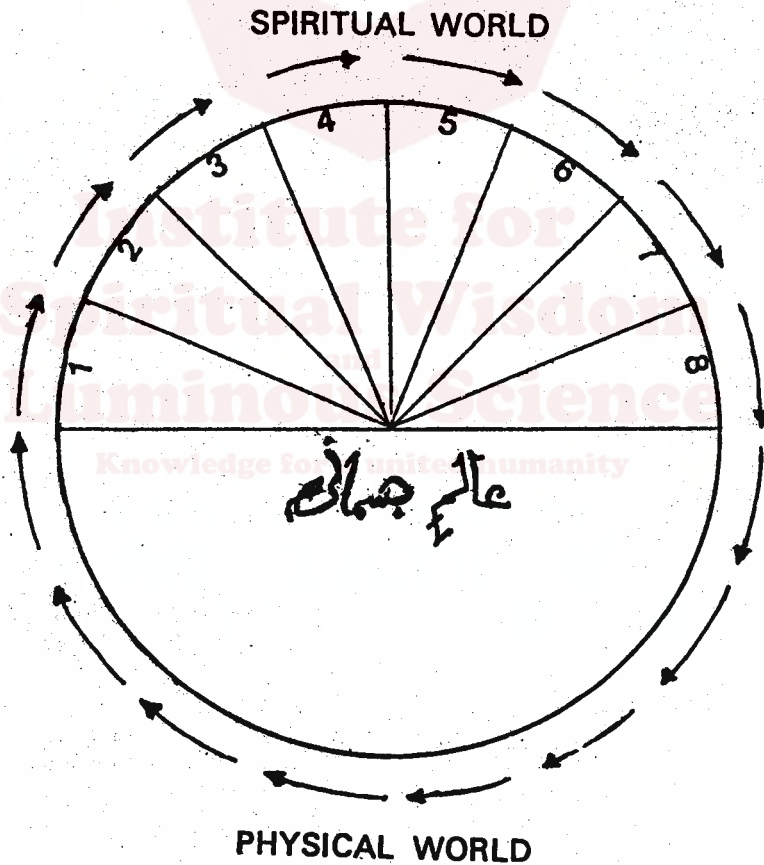

No. 55-A

89
A D A M A N D O T H E R S

We have indeed created man in the best of moulds,
then do We abase him (to be) the lowest of the low,
except such as believe and do righteous deeds: for
they shall have a reward unfailling (95: 4-6)

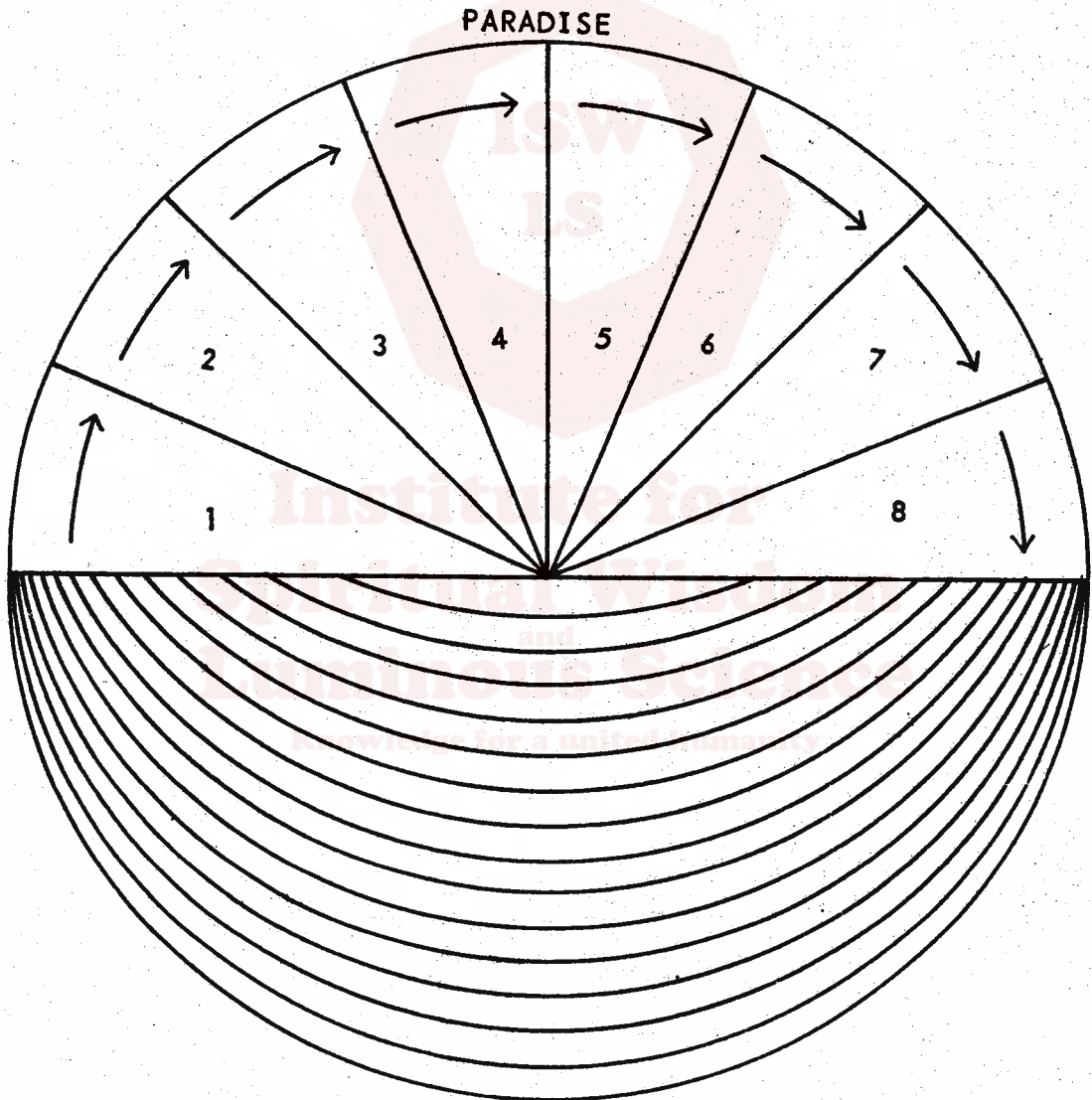

THE LOWEST OF THE LOW

TWO BOWS

BY THE STAR WHEN IT SETTETH, YOUR COMRADE ERRETH NOT,
 NOR IS DECEIVED; NOR DOTH HE SPEAK OF (HIS OWN) DESIRE.
 IT IS NAUGHT SAVE AN INSPIRATION THAT IS INSPIRED. WHICH
 ONE OF MIGHTY POWERS HATH TAUGHT HIM, ONE VIGOROUS; AND
 HE GREW CLEAR TO VIEW, WHEN HE WAS ON THE UPPERMOST
 HORIZON. THEN HE DREW NIGH AND CAME DOWN, TILL HE WAS
 (DISTANT) TWO BOWS' LENGTH OR EVEN NEARER (53 : 1-9)

SPIRITUAL BOW

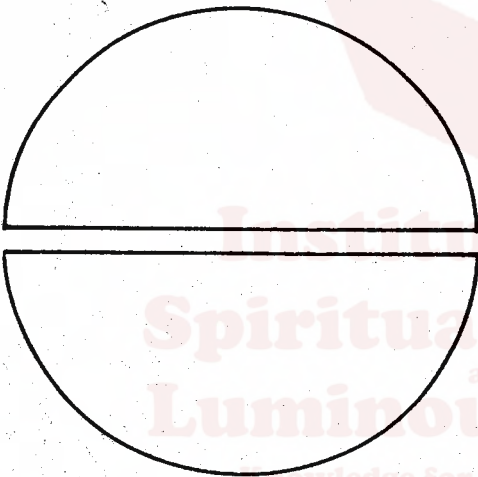

PHYSICAL BOW

UPPERMOST HORIZON

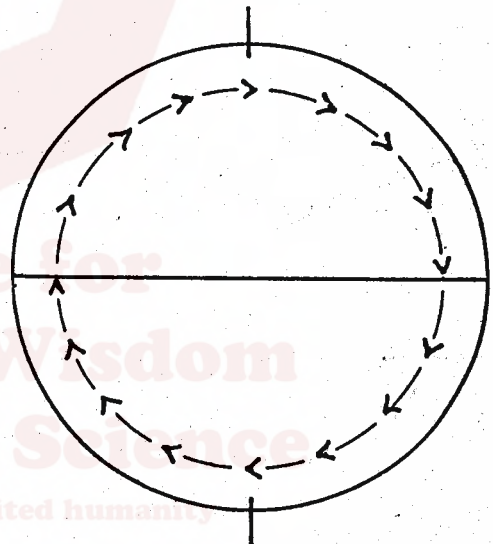

LOWEST LEVEL

GLORIFIED BE HE WHO CARRIED HIS SERVANT BY NIGHT FROM
 THE INVOLABLE PLACE OF WORSHIP TO THE FAR DISTANT PLACE
 OF WORSHIP THE NEIGHBOURHOOD WHEREOF WE HAVE BLESSED,
 THAT WE MIGHT SHOW HIM OF OUR TOKENS I LOI HE, ONLY HE,
 IS THE HEARER, THE SEER (17 : 1)

Ask the followers of the reminder (DHIKR) if ye know not (16:43,21:7)
Are those who know equal with those who know not? (39:9)

But it(Qur'ān) is clear revelations in the hearts of those who have been given knowledge (29:49)
God will exalt those who believe among you and those who have knowledge to high ranks. And God is informed of what ye do (58:11)

1

2

We (AL-QĀDĪ AL-NU'MĀN) have made it clear earlier that the reference in the Book of God is to the pure Imams of the house of the Prophet. Thus it is they who are the possessors of knowledge; it is they who are entrusted with it by God. God has distinguished them by knowledge; the light of knowledge is their special distinction. He has appointed them its guardians and

TRUE KNOWLEDGE

THE IMAMS ARE
GUARDIANS AND
TREASURERS OF
TRUE KNOWLEDGE

its treasurers and its protectors to uphold, preserve and love it.

God has bestowed on the people at large a lesser portion of knowledge than the Imams; and has commanded the community to ask the Imams concerning things which they know not.

God has elevated the Imams by their guardianship of the people, and thus has He honoured the Imams by the command to seek knowledge from them

3

91

4

and to obey their behests and constituted obedience to the Imams an essential part of the people's faith. From the Prophet, on the authority of the Imams. He said: the best minister of knowledge is gentleness; the best minister of gentleness is affection; and the best minister of affection is lenity.

No. 57

THREE EXAMPLES OF THE SAME REALITY

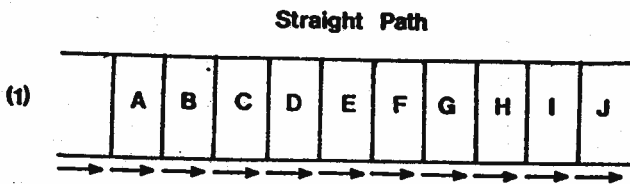
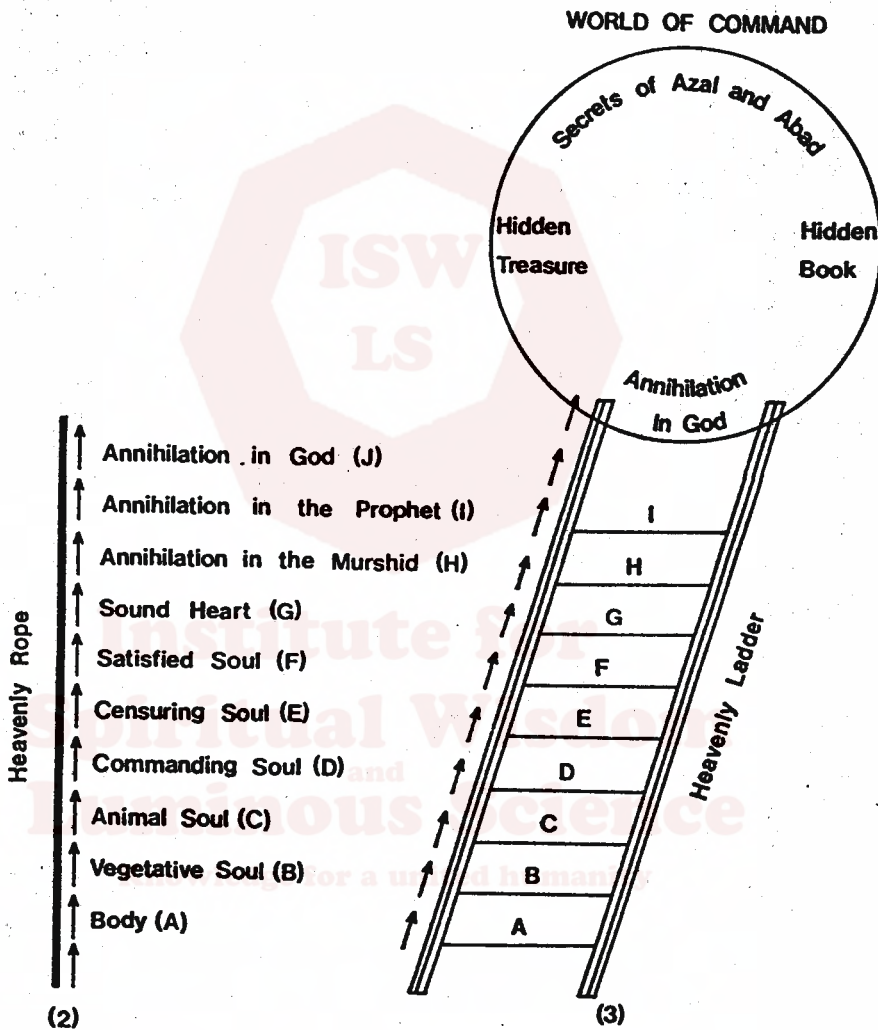

Diagrams of Wisdom

(Nuqūsh-i Hikmat)

by

‘ALLĀMAH

NAṢĪR AL-DĪN "NAṢĪR" HUNZĀ’Ī

Published by:

KHĀNAH-I HIKMAT/IDĀRAH-I ‘ĀRIF